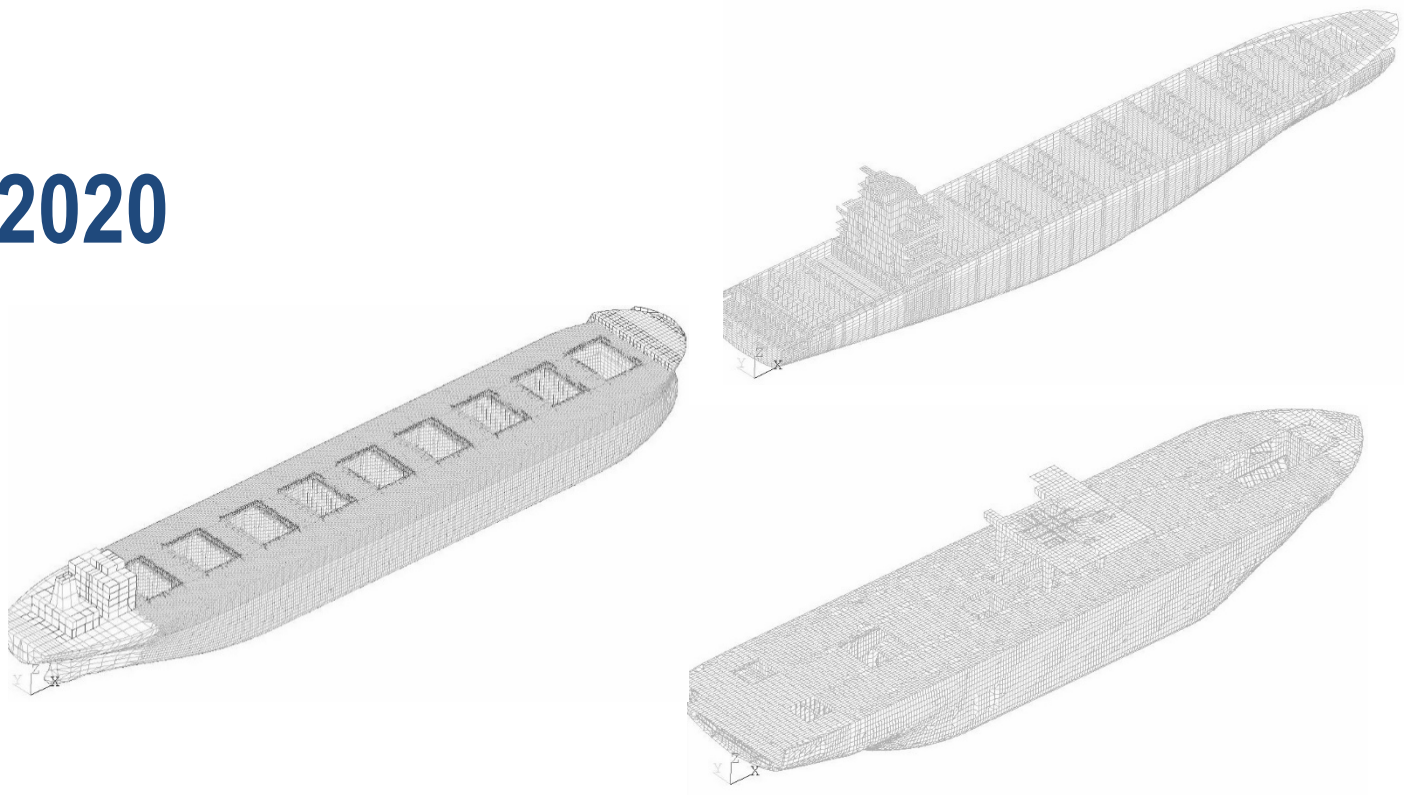


# Guidelines on Structural Assessment of Ships based on Finite Element Method

2020



**IRCLASS**  
Indian Register of Shipping

**History of Revision/Updates**

- First publication: December 2020

---

# CONTENTS

## Section 1

### General Principles

- 1.1 General
- 1.2 Scope
- 1.3 Finite element analysis
- 1.4 Global co-ordinate system
- 1.5 Documentation requirements

## Section 2

### Full Ship Strength Analysis

- 2.1 Scope and application
- 2.2 Full ship structural model
- 2.3 Loads
- 2.4 Load application
- 2.5 Analysis criteria

## Section 3

### Cargo Hold Analysis

- 3.1 Scope and application
- 3.2 Cargo hold definition
- 3.3 Cargo hold FE analysis methodology
- 3.4 Structural modelling
- 3.5 Boundary conditions
- 3.6 Loads and FE load combinations
- 3.7 Load application
- 3.8 Hull girder loads
- 3.9 Analysis criteria

## Section 4

### Local Structural Strength Analysis

- 4.1 Scope and application
- 4.2 Local areas to be assessed by fine mesh
- 4.3 Structural model
- 4.4 Screening procedure
- 4.5 Loads and FE load combinations
- 4.6 Analysis criteria

**Appendix A**  
**Screening procedure**

**Abbreviations**

AP	:	Aft perpendicular
BL	:	Base line
CG	:	Centre of gravity
CL	:	Centre line
EDW	:	Equivalent design wave
FE	:	Finite element
FP	:	Forward perpendicular
LCB	:	Longitudinal centre of buoyancy
LCF	:	Longitudinal centre of flotation
LCG	:	Longitudinal centre of gravity
RAO	:	Response amplitude operator
TCG	:	Transverse centre of gravity
VCG	:	Vertical centre of gravity

**Coordinate System**

The coordinate system is defined as follows:

<b>Origin</b>	:	AP, CL, BL
<b>+ve X axis</b>	:	Along the ship's length from Aft to Fore
<b>+ve Y axis</b>	:	Along the Ship's beam from CL to Port
<b>+ve Z axis</b>	:	Along the Ship's depth from Baseline

---

## Section 1

### General Principles

#### General

- 1.1.1 This document is intended to provide guidelines for performing structural assessment of ships using the finite element (FE) method.
- 1.1.2 A general description of relevant FE analyses are given in these guidelines.
- 1.1.3 Scope and details of the applied procedures/methods are also provided in the relevant sections.

#### Scope

- 1.2.1 These guidelines are to be used in conjunction with the latest *IRS Rules and Regulations for the Construction and Classification of Steel Ships* (hereinafter referred to, as the Rules)
- 1.2.2 IRS Rules will prevail in case of any differences between the Guidelines and Rules.
- 1.2.3 Established / standard computer software/programs are to be used for the finite element analyses herein.
- 1.2.4 The additional class notation **DSA (Direct Strength Analysis)** will be assigned to vessels where a structural strength assessment has been carried out in accordance with the relevant requirements of the Rules, provisions of these Guidelines and the '*Guidelines on Application of Direct Seakeeping Loads in Structural Analysis of Ships*' (IRS-G-DES-06).

#### Finite Element Analysis

- 1.3.1 General
  - 1.3.1.1 These guidelines cover the following approaches to perform strength assessment of ship structures based on finite element method namely:
    - (a) Full ship analysis, to assess the global structural strength and deformations of the hull girder primary structure as specified in Section 2. This is recommended for ships as specified in Section 2 (refer Section 2).
    - (b) Cargo hold analysis, to assess the strength of primary structural members within the cargo hold region (refer Section 3).
    - (c) Local structural strength analysis, to assess the local structural strength and detailed stress levels (refer Section 4).
  - 1.3.2 Net Scantling Approach
    - 1.3.2.1 Net Scantling approach is to be used for structural assessment based on FE given in present guide.
    - 1.3.2.2 In the "Net Scantling Approach", the required gross scantling is obtained by adding the net scantling obtained from the structural strength requirement to the total corrosion addition as defined below:

$$t_{\text{gross\_required}} = t_{\text{net\_required}} + t_c$$

The total corrosion addition,  $t_c$  in [mm], for both sides of the structural member is obtained by the following formula:

$$t_c = t_{c1} + t_{c2} + t_{res}$$

where,

$t_{c1}, t_{c2}$  = Corrosion addition, in [mm], on each of the two sides of the considered structural member, as defined in Table 1.3.2.1.

$t_{res}$  = Reserve thickness, taken as 0.5[mm], also to be applied in non-corrosive environment and for stainless steel and aluminium to account for possible thickness reductions, e.g. wear and tear, grinding or under tolerance thickness.

**Table 1.3.2.1: Corrosion addition for one side of a structural member**

Sl.No.	Compartment Type	Structural Member	Corrosion Addition (tc1 or tc2)	
			General	Special case
1	Tanks for Ballast water <sup>1)</sup> /Sea water	All members <sup>7)</sup>	1.00	1.25 <sup>2)</sup>
2	Tanks for Cargo Oil <sup>1)</sup> and Slop Tank	All members	1.00	1.25 <sup>2)</sup>
3	Tanks for Liquid Chemical	All members	1.00	
4	Tanks for fuel oil, lube oil	All members	0.50	1.00 <sup>2)</sup>
5	Tanks for Brine, Urea, Bilge Tank, Drain Storage, Chain Locker	Face plates of PSM's	1.00	
		Other members	1.00	
6	Tanks for fresh water	All members	0.50	
7	Other tanks - cargo tanks only intended to carry fresh water, fuel oil, lube oil, RSW or mud.	All members	0.50	
8	Dry Bulk Cargo <sup>3)</sup>	General	1.00	
		Inner bottom plating	1.50	
		Sloping stool plate of hopper tanks and lower stool		
		Transverse bulkhead plating		
		Brackets, Frames, ordinary stiffeners and primary supporting members	1.00	1.5 <sup>4)</sup>
9	Containers and General cargo hold	All members in hold	1.00	
10	Accommodation spaces <sup>5)</sup>	All members	0.00	

11	Void, dry spaces and other category spaces not mentioned above <sup>6)</sup> .	All members	0.50	
12	Stainless steel and aluminium (independent of compartment type)	All members	0.00	
13	External Surfaces	All members	0.50	
<p>(1) Ballast tank: also includes combined ballast and cargo oil tanks but does not include cargo oil tanks which may carry ballast according to Regulation 18 of MARPOL 73/78 as amended.</p>				
<p>(2) This minimum corrosion addition is applied in the area within 1.5[m] below the top of the tank. This is applied to ballast or liquid cargo tanks with exposed weather deck as the tank top.</p>				
<p>(3) Dry bulk cargo hold includes holds intended for the carriage of dry bulk cargoes, which may carry oil or water ballast.</p>				
<p>(4) This minimum corrosion addition is applied in the area within 1.5[m] above the bottom of hold, e.g. inner bottom. The bottom of hold is defined as the lowest horizontal boundaries of the hold.</p>				
<p>(5) When not covered by any sheeting, AC Room, galleys, technical areas and crew staircases are to be considered as "other compartments"</p>				
<p>(6) Applicable for the spaces containing membrane or independent cargo tanks of gas carriers. Also applicable for semi-enclosed compartments, e.g. open ro-ro spaces.</p>				
<p>(7) 0.5 [mm] is to be added to the plate surface exposed to ballast for the plate boundary between water ballast and heated cargo oil tanks or heated fuel/lube oil tanks/slop tanks. 0.3[mm] is to be added to each surface of the web and face plate of a stiffener in a ballast tank and attached to the boundary between water ballast and heated cargo oil tanks or heated fuel/lube oil tanks/slop tanks. Heated oil tanks are defined as tanks/slop tanks arranged with any form of heating capability (the most common type is heating coils).</p>				
<p>(8) Dry bulk cargo carriers refers to the cargo holds of vessels with class notations BC-A, BC-B, BC-C or Ore Carrier. For single skin bulk carriers of length &gt; 150[m], <math>t_{\min} = 3.5</math> [mm].</p>				



1.3.3 Types of finite elements used

- 1.3.3.1 General types of finite elements to be used for the finite element analysis are indicated in Table 1.3.3. The over-arching objective is to model the stiffness of the primary and structural members as accurately as practicable.
- 1.3.3.2 Two node beam/link elements and four node shell elements are, in general, considered sufficient for the idealization of the primary and secondary supporting members of the hull structure. Plates are to be modelled using shell element and stiffeners are to be modelled as beam elements. The mesh requirements given in subsequent sections assume that these elements are used in the finite element models. Higher order elements can be used for complex geometries or high stress gradient regions.
- 1.3.3.3 Usually, the aspect ratio of the shell elements is not to exceed 2. The use of triangular shell elements is to be kept to a minimum. Wherever possible, the aspect ratio of shell elements in areas where there is a likelihood for high stresses or a high stress gradient is to be kept close to 1.
- 1.3.3.4 For quadrilateral-shaped shell element, an angle greater than 135° and smaller than 45° is not recommended. Triangular elements are to be avoided to the extent practicable. The limiting range for triangular shell element is 45° to 90°, if used.
- 1.3.3.5 Only shell elements are to be used for fine mesh analysis.

**Table 1.3.3: Types of finite elements used**

Types of finite element	Description
Rod (or truss) element	Line element with axial stiffness only and constant cross-sectional area along the length of the element.
Beam element	Line element with axial, torsional and bi-directional shear and bending stiffness and with constant properties along the length of the element.
Shell (or plate) element	Shell element with in-plane stiffness and out-of-plane bending stiffness with constant thickness.

1.3.4 FE model check

- 1.3.4.1 The FE model is to be checked in order to ensure that there is adequate representation of the geometry, stiffness and mass in the model with respect to the actual ship. The following checks for verification are recommended, but not limited to:
  - (a) Geometric properties of structure (e.g. extent of geometry, structural idealization, effect of geometrical simplifications like omission of cuts-out etc.)
  - (b) Material properties of structure (e.g. linear elastic, isotropic, anisotropic, orthotropic)
  - (c) Stiffness properties of structures (e.g. moment of inertia, section modulus, neutral axis)
  - (d) Mass properties (e.g. mass of individual tanks and the locations of their centre of gravity (CG), overall mass and their CG location)
  - (e) Element types (e.g. suitable element type is used for representation of beams and plates)
  - (f) Mesh size (e.g. aspect ratio, angle of distortion, shape error, adequate mesh.
  - (g) Connectivity of the finite element model to ensure there are no free nodes/elements or overlapping nodes and elements.

- (h) Applied loads and boundary conditions (BC).
- (i) Check for possible modelling errors e.g. double elements, elements not connected to other element edge, elements with irregular shape etc.

### Global co-ordinate system

- 1.4.1 The following co-ordinate system is recommended: right hand co-ordinate system, with the x-axis positive forward, y-axis positive to port and z-axis positive vertically from baseline to deck. The origin should be located at the intersection between aft perpendicular (AP), baseline and centreline. The co-ordinate system is illustrated in *Figure 1.4.1* along with the definition of positive motion.
- 1.4.2 It should be noted that, in case of *Part 3* of the Rules, the reference coordinate is defined at AE of Rule length 'L'.
- 1.4.3 The sign conventions (Refer *Figure 1.4.2*) for hull girder loads are as follows:
- The vertical bending moments  $M_{sw}$  and  $M_{wv}$  are positive when they induce tensile stresses in the strength deck (hogging bending moment) and negative when they induce tensile stresses in the bottom (sagging bending moment).
  - The vertical shear forces  $Q_{sw}$ ,  $Q_{wv}$  are positive in the case of downward resulting forces acting aft of the transverse section and upward resulting forces acting forward of the transverse section under consideration.
  - The horizontal bending moment  $M_{wh}$  is positive when it induces tensile stresses in the starboard side and negative when it induces tensile stresses in the port side.
  - The torsional moment  $M_{wt}$  is positive in the case of resulting moment acting aft of the transverse section following negative rotation around the X-axis, and of resulting moment acting forward of the transverse section following positive rotation around the X-axis.

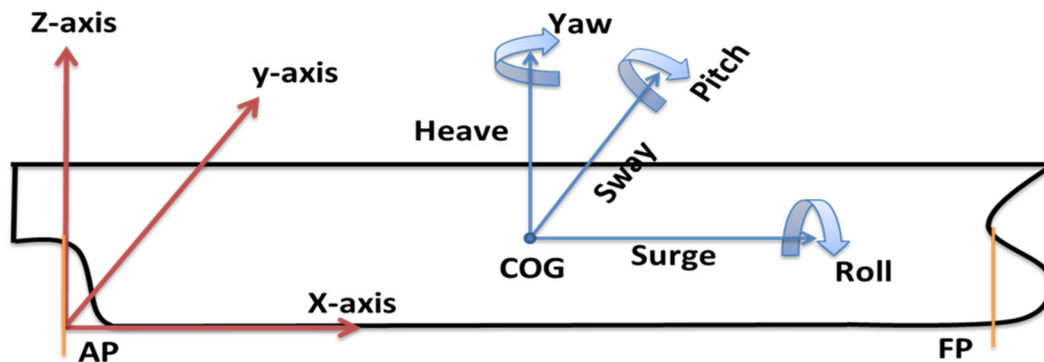
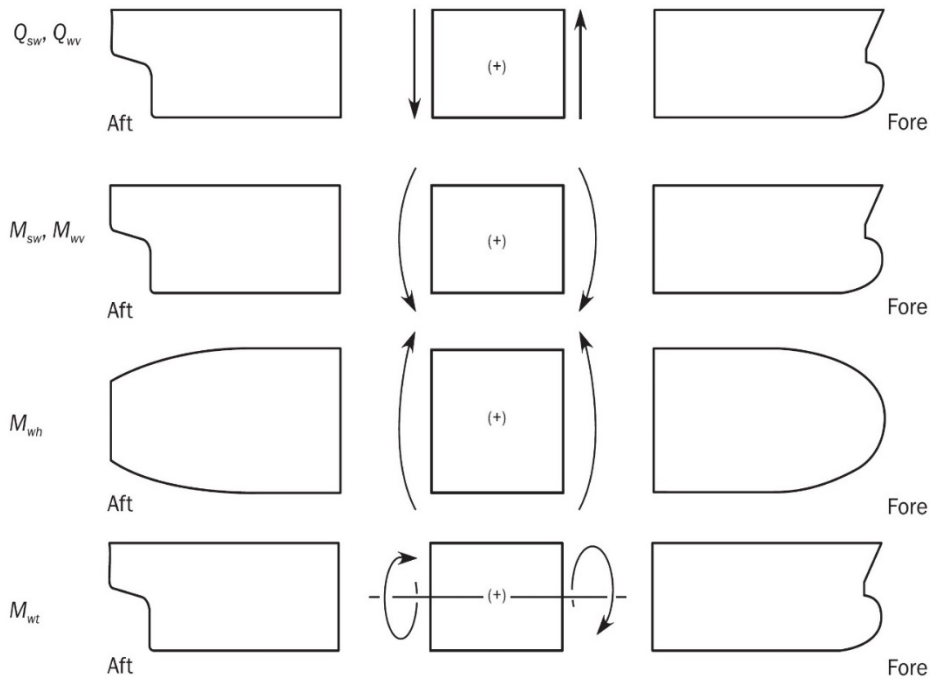


Figure 1.4.1: Reference coordinate system and definition of positive motions



**Figure 1.4.2: Sign convention for hull girder loads**

## Documentation requirements

1.5.1 Detailed documentation is to be submitted in order to demonstrate compliance with the specified structural design criteria. The complete documentation would typically include:

- (a) Drawings and sketches of the subject structure.
- (b) Detailed description of structural modelling including all modelling assumptions and any deviations in geometry and arrangement of structure compared with plans.
- (c) Plate thickness plots, beam sections plot for all decks, profiles and transverse sections.
- (d) Details of boundary conditions.
- (e) Details of all loading conditions reviewed with calculated hull girder shear force, bending moment and torsional moment distributions.
- (f) Details of applied loads and confirmation that individual and total applied loads are correct.
- (g) Plots and results of structural analyses carried out.
- (h) Summary and plots of deflections.
- (i) Plots of stresses (von-mises, and in-plane stress components) for all decks, profiles and transverse sections to demonstrate that the yield design criteria are not exceeded in any member.
- (j) Plate and stiffened panel results utilization ratios in buckling/ultimate strength failure mode.
- (k) Tabulated results showing compliance, or otherwise, with the design criteria.
- (l) Proposed amendments to scantling, including revised assessment of stresses, yield, buckling and fatigue checks showing compliance with design criteria
- (m) Computer program used in analysis (including its version and date).

---

## Section 2

### Full Ship Strength Analysis

#### 2.1 Scope and application

##### 2.1.1 General

2.1.1.1 This section includes detailed guidelines for performing full ship strength analysis as required by the Rules in *Part 3* and in *Part 5*.

2.1.2 Full ship strength analysis is intended to evaluate and assess the global stresses and deformations of the hull girder. Full ship analysis is typically required for the following:

- (a) Ships with novel structural design and arrangement
- (b) Ships with large deck openings (e.g. container ships).
- (c) Ships without or with limited transverse bulkheads over the length of ship (e.g. Ro-Ro ship or car carrier)
- (d) Passenger ships ( $L > 150\text{m}$ ) with partly effective superstructure and/or partly effective upper part of hull girder

#### 2.2 Full ship structural model

##### 2.2.1 Extent of Model

2.2.1.1 A three-dimensional model of the full ship representing the entire hull structure is to be created. All primary and most secondary structural members are to be modelled in order to accurately simulate the stiffness of the hull girder.

2.2.1.2 Both port and starboard sides are to be modelled. Any structural items that do not contribute to the global strength may be disregarded although the masses of these said items are to be included appropriately into the model.

2.2.1.3 Mass modelling and loads application are to be performed in accordance with IRS Guidelines *IRS-G-DES-06*.

2.2.1.4 Large openings in the structure are to be represented adequately using the method given in *Section 3, [3.4.4.5]*.

2.2.1.5 Typical full ship models are shown in *Figure 2.2.1 (a)* and *Figure 2.2.1 (b)*.

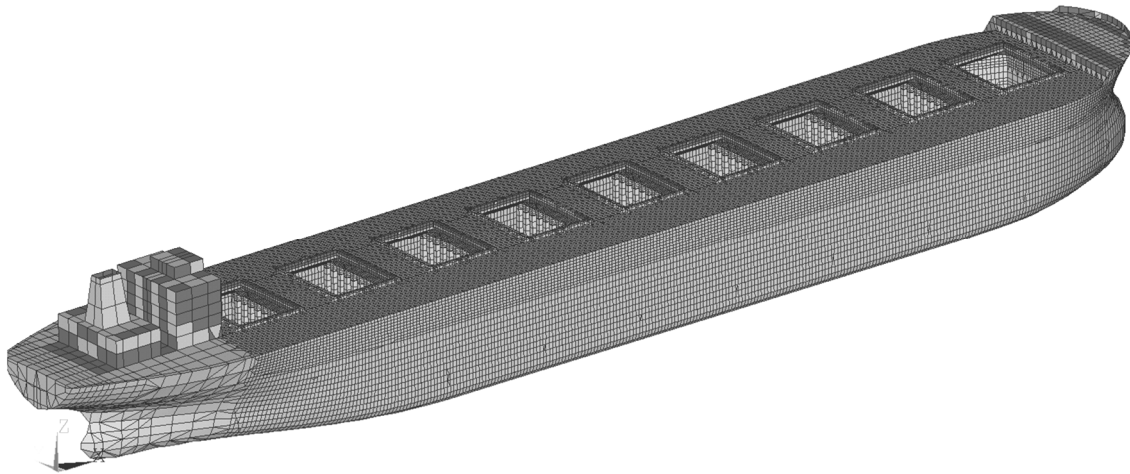
##### 2.2.2 Meshing

2.2.2.1 Mesh size should be selected to accurately represent the geometry of the stiffness considered structure (e.g. overall geometry, stiffeners locations, arrangement such that the grid points are located at the intersection of primary members) and the load distribution.

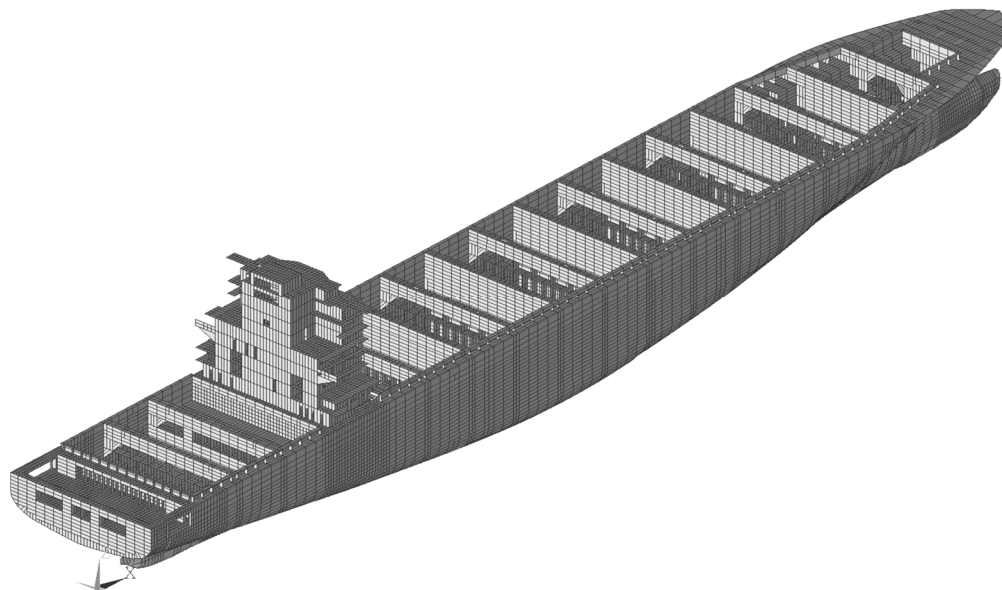
2.2.2.2 It is recommended that, elements are sized such that there is at least one element between two stiffeners and at least three elements between two web frames. It is recommended to maintain the aspect ratio of the elements below 2.0. Element sizes may be refined near openings in order

to capture the stress gradients accurately. It is recommended to avoid triangular elements as far as possible within the finite element model.

- 2.2.2.3 Finer mesh generation can be done in a local structure where refined stress distribution is needed. The finer mesh model may be included as part of the full ship structural model or analysed separately as per [2.2.2.4]. Local structure is to be provided with all the relevant geometric details and appropriate mesh density in global model.
- 2.2.2.4 A separate analysis of local structure can be performed using sub-modelling technique. The displacements from global model are taken as the boundary conditions. More details are to be referred from Section 4.



**Figure 2.2.1 (a): Full ship model of a Bulk Carrier**



**Figure 2.2.1 (b): Full ship model of a Container ship**

2.2.3 Boundary conditions

2.2.3.1 Buoyant condition of full ship FE model in static structural analysis is to be simulated by providing artificial supports. Boundary conditions are applied to prevent the rigid body motions without over-constraining the model. These support reactions are not to exceed [1]% of the displacement of the ship. Location of boundary condition is to be far away from the area of interest. Generally, boundary conditions are typically applied at two locations, one in the aft and the other in the fore. A Typical example of boundary conditions is indicated in *Table 2.2.3* and *Figure 2.2.*

Table 2.2.3: Boundary conditions for global model		
	Location	Direction
Engine Room Front Bulkhead	SB & PS	Z
	CL	Y
Collision Bulkhead	CL	X, Y, Z

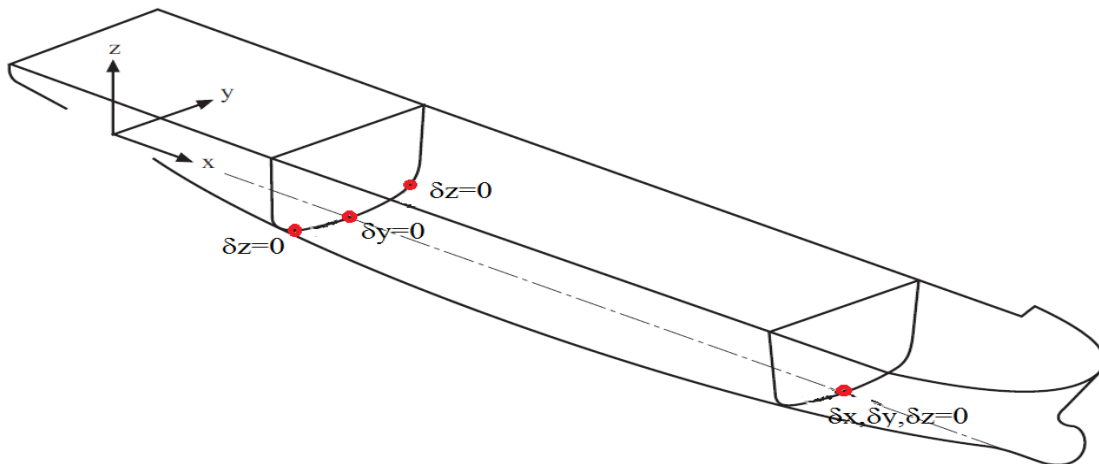


Figure 2.2.3: Boundary conditions

2.3 Loads

- 2.3.1 A general overview of full ship structural strength analysis is given in *Figure 2.3.1*. The procedure given in *Figure 2.3.1* is to be followed to calculate the maximum loads.
- 2.3.2 Most representative loading conditions typically found in the loading manual are to be considered for the full ship analysis. Other cargo loading conditions that may be deemed critical may also be considered in the full ship analysis. The need to consider other loading conditions or additional loading conditions is to be determined in consultation with IRS.
- 2.3.3 Loading conditions are to be considered in accordance with Part 3 of the Rules. For specific ship types, refer Part 5 of the Rules.
- 2.3.4 The procedure given in *Figure 2.3.1*, includes the calculation of long term response for each 'Maximum Load Situation' as defined in [2.4]. It is calculated for various loading conditions based on environmental data (scatter table) and the ship's Response Amplitude Operator (RAOs). The

long-term response refers to the most probable extreme value at the given probability level of exceedance which is generally taken as  $10^{-8}$  for a design life of 25 years.

- 2.3.5 The Equivalent Design Wave (EDW) is defined as a regular wave which provides the long-term extreme value of the maximum load situation under consideration. The equivalent design wave can be characterized by e.g. wave height, wave length, wave heading, wave crest position referenced to the amidships. For each of the Maximum Load Situations [see 2.4], an equivalent design wave is to be determined. Simultaneous load components acting on the hull structure are to be generated for that design wave at the specific time instant when the corresponding Maximum Load Situation reaches its maximum.
- 2.3.6 The ship motion and wave loads are to be calculated for the calculated equivalent design wave. Non-linear seakeeping analysis is recommended to be performed to effectively account for instantaneous nonlinear effects during the time simulation.

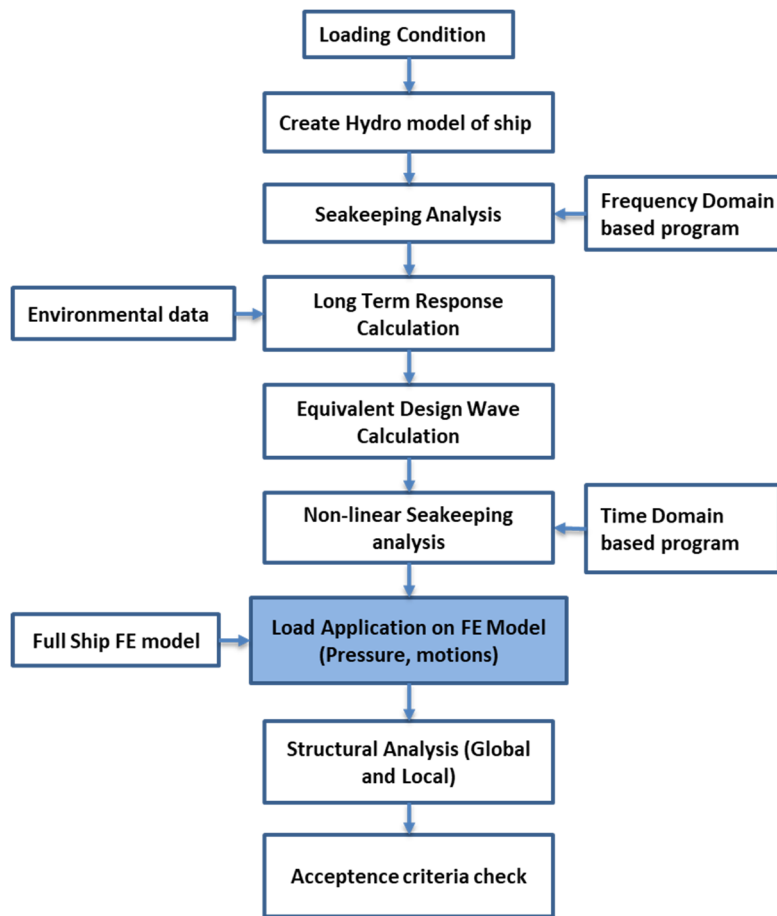


Figure 2.3.1: Schematic representation of full ship Strength Analysis

- 2.3.7 To develop the loads for structural FE analysis, load cases are to be prepared considering the loading conditions, ship’s speed and maximum load situations. It includes the both static and dynamic components. The dynamic loads represent the combined effects of a maximum load situation and other accompanying loads acting simultaneously on the hull structure, if any. It contains the loads e.g. external wave pressures, internal tank pressures, bulk cargo loads,

container loads and inertial loads on the structural components and equipment. The load application is to be considered in accordance with [2.5].

- 2.3.8 For each load case, the developed loads are then used in the FE analysis to determine the resulting stresses and other load effects within the hull structure. The acceptance criteria are to be checked in accordance with [2.6].

## 2.4 Maximum Load Situation

- 2.4.1 The load effects due to ship motion and accelerations create a situation where the ship structure receives the highest loads on structural members. This kind of situation can be checked by the following parameters:

- Maximum vertical bending moment at midship (sagging and hogging see Figure 1.4.2)
- Maximum vertical shear force (positive and negative see Figure 1.4.2)
- Maximum horizontal bending moments at midship (positive and negative, see Figure 1.4.2)
- Maximum torsional moment in vessels having large openings (positive and negative see Figure 1.4.2)
- Maximum vertical accelerations (upwards and downwards, see Figure 1.4.1)
- Maximum lateral accelerations (portside and starboard side see Figure 1.4.1)
- Maximum roll (positive and negative, see fig. Figure 1.4.1).

## 2.5 Load application

- 2.5.1 All the relevant loads (e.g. external sea-pressure, local loads, inertial loads etc.) are to be applied on the FE model. IRS Guidelines *IRS-G-DES-06* are to be referred for more details on application of sea-keeping loads on full ship FE model.

## 2.6 Analysis criteria

### 2.6.1 General

- 2.6.1.1 The analysis criteria that apply for full ship FE model are described in this sub-section. Structural adequacy of hull girder structural members, primary and secondary structural members is to be checked. FE analysis results for failure mode of material yielding, buckling and fatigue are to be checked. Wherever, the full ship FE model is partially or entirely refined to a mesh arrangement as used in cargo hold analysis (*Section 3*) or local structural analysis (*Section 4*); the analysis criteria given in respective and relevant sections are to be applied.

### 2.6.2 Yield strength assessment

- 2.6.2.1 For all plates/shell elements, the von Mises stress,  $\sigma_{vm}$  [N/mm<sup>2</sup>] are to be calculated based on the membrane normal and shear stresses of the shell elements. The stresses are to be evaluated at the element centroid of the mid-plane (layer), as follows:

$$\sigma_{vm} = \sqrt{\sigma_x^2 - \sigma_x\sigma_y + \sigma_y^2 + 3\tau_{xy}^2}$$

where,

$\sigma_x, \sigma_y$  : Element normal membrane stresses, in [N/mm<sup>2</sup>]

$\tau_{xy}$  : Element shear stress, in [N/mm<sup>2</sup>]



2.6.3 Buckling strength assessment

2.6.3.1 Applicable structural locations/details/members are to be selected and evaluated as provided in the *IRS Rules for Bulk Carriers and Oil Tankers*, Volume 2, Chapter 8 for buckling strength assessment.

2.6.3.2 IRS will specially consider buckling strength evaluation using non-linear finite element techniques in lieu of the provisions on 2.5.3.1. For this purpose, it has to be demonstrated to the satisfaction of IRS that the program using non-linear finite element techniques gives satisfactory results. The program is to be able to consider the effects of initial imperfections in the plating according to IACS Recommendation. 47 and residual stresses.

2.6.4 Fatigue strength assessment

2.6.4.1 Applicable structural locations/details/members are to be selected as indicated in IRS Rules Part 3 and Part 5 and IRS Guidelines *IRS-G-DES-07* for fatigue strength assessment.

---

## Section 3

### Cargo Hold Analysis

#### 3.1 Scope and application

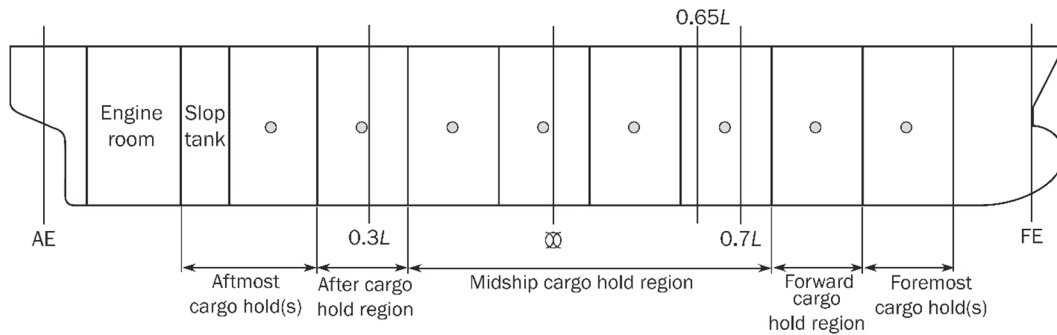
- 3.1.1 This section gives the requirements for finite element based structural strength analysis of cargo hold region. It is performed to assess the strength of longitudinal hull girder structural members, primary supporting structural members and bulkheads within cargo hold region as specified in [3.2].
- 3.1.2 Strength analysis of mid-ship cargo hold region is mandatory for the following ships. The definition of cargo hold region is given in [3.2];
- Ships having rule length  $L > 150$ [m]
- The regions other than mid-ship cargo hold will be considered by the IRS, if necessary.
- 3.1.3 Cargo hold structural strength analysis covers the cargo hold region including the aft bulkhead of the aft most cargo hold and the collision bulkhead in accordance to Section 3, [3.1.2]. The evaluation areas are defined in [3.9.1].
- 3.1.4 The procedures of cargo hold analysis may also be used for fatigue analysis as indicated in IRS *Guidelines IRS-G-DES-07*. The local structural mesh density is to be taken as indicated in *Section 4* and IRS *Guidelines IRS-G-DES-07*.

#### 3.2 Cargo hold definition

- 3.2.1 For the purpose of FE structural assessment and load application, the term cargo hold region refers to the following cargo hold regions, which may vary depending on the ship length and cargo hold arrangement, as defined in *Figure 3.2.1 (a)*:
- Mid-ship cargo hold region
  - Forward cargo hold region
  - After cargo hold region
  - Foremost cargo hold(s)
  - Aft most cargo hold(s)

#### 3.2.2 Evaluation area

The evaluation area is an area in the partial ship model, where the verification of results against the acceptance criteria are to be carried out. For a cargo hold structural analysis, evaluation area is defined in [3.9.1]



**Figure 3.2.1(a): Definition of cargo hold regions for FE structural assessment**

- Holds in the forward cargo hold region are defined as holds with their longitudinal centre of gravity position forward of 0.7 L from AE, except foremost cargo hold.
- Holds in the mid-ship cargo hold region are defined as holds with their longitudinal centre of gravity position at or forward of 0.3 L from AE and at or aft of 0.7 L from AE.
- Holds in the after cargo hold region are defined as holds with their longitudinal centre of gravity position aft of 0.3 L from AE, except aft most cargo hold.
- Foremost cargo hold(s) is (are) defined as hold(s) in the foremost location of the cargo hold region.
- Aft most cargo hold(s) is (are) defined as hold(s) in the aft most location of the cargo hold region.

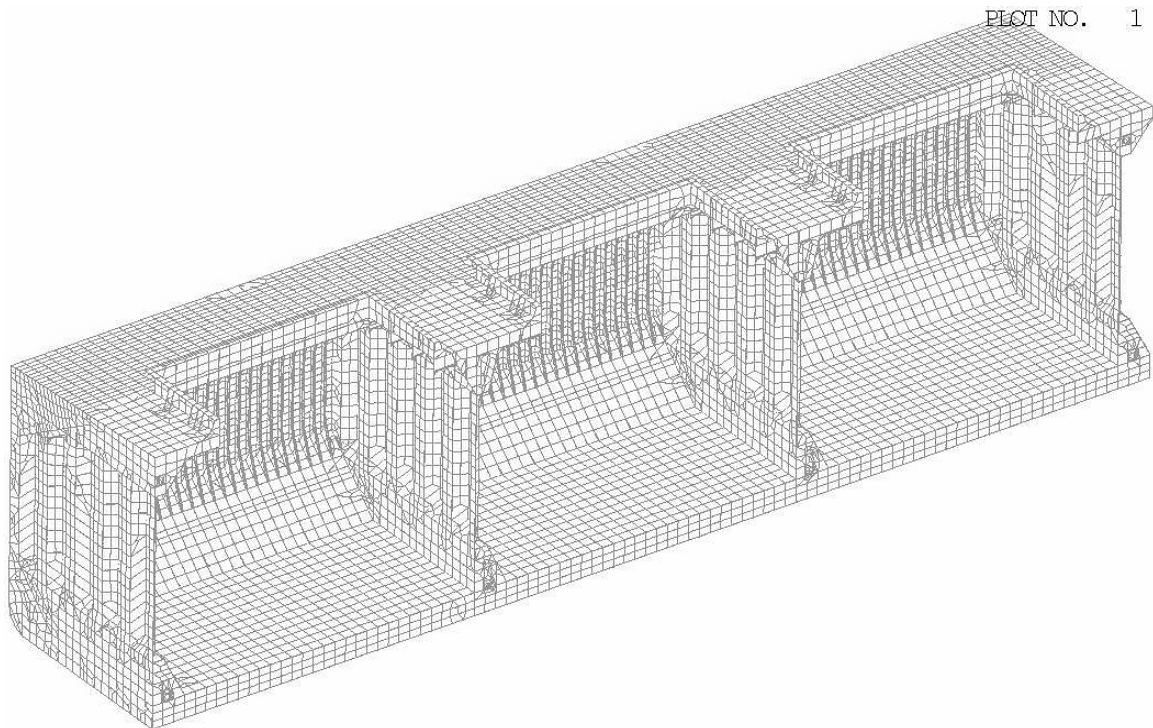


Figure 3.2.1 (b): Example of a three cargo hold model of a bulk carrier (shown the port side of the full breadth model)

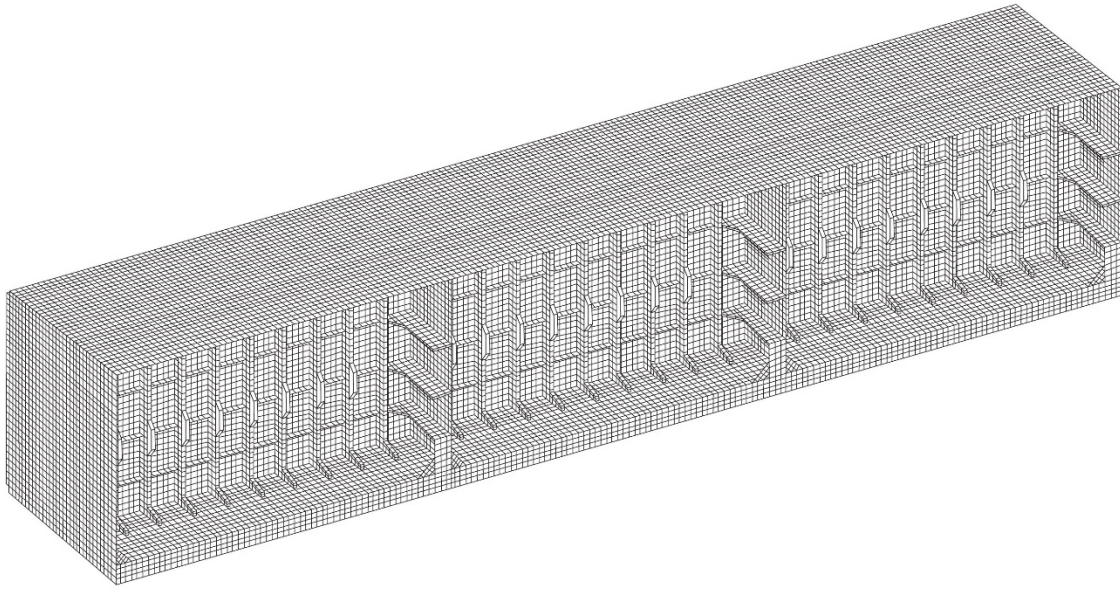


Figure 3.2.1 (c): Example of a three cargo hold model of an oil tanker (with port side of the full breadth model visible)

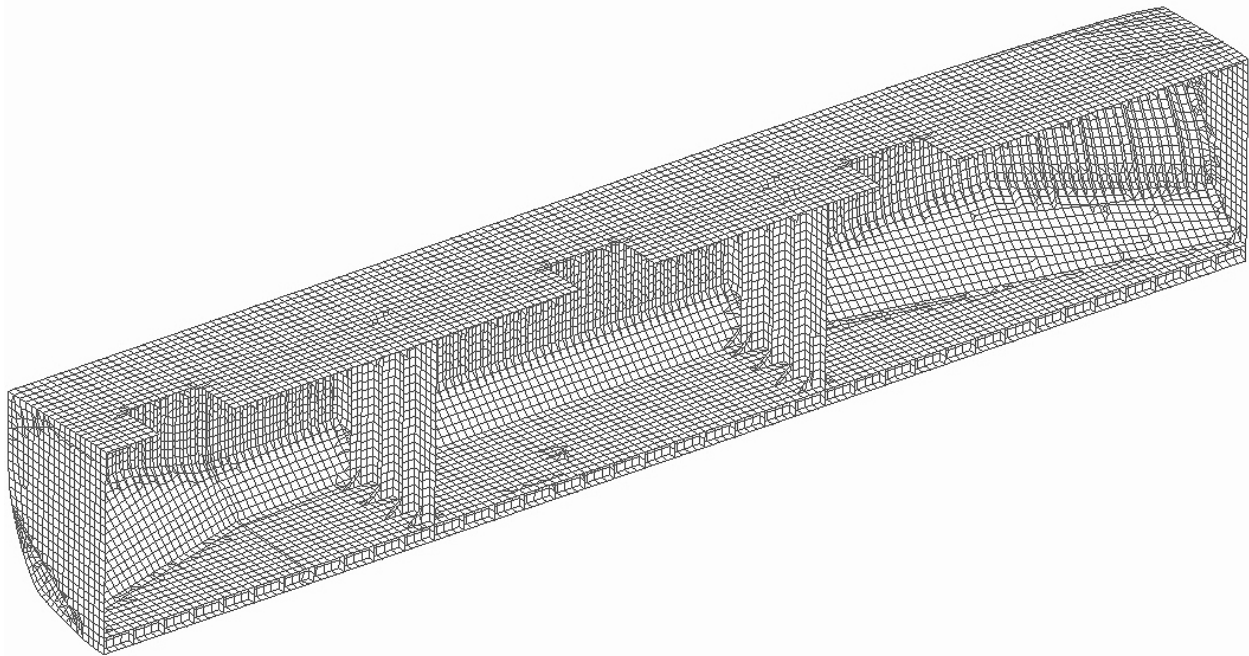
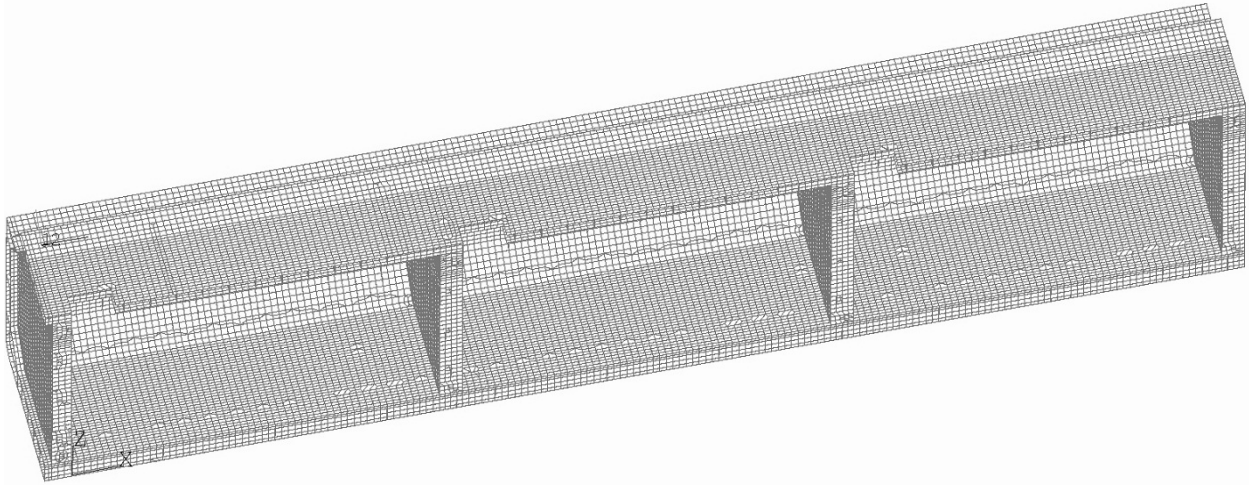


Figure 3.2.1 (d): Example of a three cargo hold model of an LPG carrier (with port side of the full breadth model visible)



**Figure 3.2.1 (e): Example of a three cargo hold model of an LNG carrier (with port side of the full breadth model visible)**

### 3.3 Cargo hold FE analysis methodology:

3.3.1 The procedure for performing cargo hold FE structural analysis is as follows

- Structural modelling of three cargo hold model as defined in [3.4]
- Boundary conditions as defined in [3.5]
- FE load combinations as defined in [3.6]
- Load application as defined in [3.7]
- Evaluation area as defined in [3.9.1]
- Strength assessment as defined in [3.9.3] and [3.9.4]

3.3.2 Corrosion margin is to be applied (for calculation of sectional properties such as sectional area, sectional moment of inertia etc.) as specified in *Section 1*, [1.3.2].

### 3.4 Structural modelling

3.4.1 Structural elements to be modelled

3.4.1.1 All main longitudinal and transverse structural elements within the extent of three hold model are to be modelled. These include the following:

- Inner and outer shell
- Deck
- Double bottom floors and girders

- 
- Transverse and vertical web frames
  - Hatch coming
  - Stringers
  - Transverse and longitudinal bulkhead structures
  - Outer primary supporting members
  - Other structural members which contribute to hull girder strength

3.4.1.2 All plates and stiffeners on the structure, including web stiffeners are to be modelled. Large brackets which contribute to the strength of primary supporting members are also to be modelled.

### 3.4.2 Model extent

#### 3.4.2.1 General

(a) For the purpose of the FE analysis, the mid-hold is defined as the middle hold(s) of the three cargo hold length FE model. In case of foremost and aft-most cargo hold assessment, the mid-hold represents the foremost and aft-most cargo hold including the slop tank if any, respectively. The extent of the model for cargo hold analysis is such that the model boundaries are adequately remote from the evaluation area/mid-hold.

#### 3.4.2.2 Longitudinal extent

Except for the foremost and aft most cargo hold models, the longitudinal extent of the cargo hold FE model is to cover three cargo hold lengths. The transverse bulkheads at the ends of the model are to be modelled. Where corrugated transverse bulkheads are fitted, the model is to include the extent of the bulkhead stool structure forward and aft of the tanks/holds at the model ends. The web frames at the end of the model are to be modelled. Typical finite element models representing the mid-ship cargo hold region of different ship type configurations are shown in *Figures 3.2.1(b) to Figure 3.2.1(e)*.

#### 3.4.2.3 Transverse extent:

Both port and starboard sides of the ship are to be modelled.

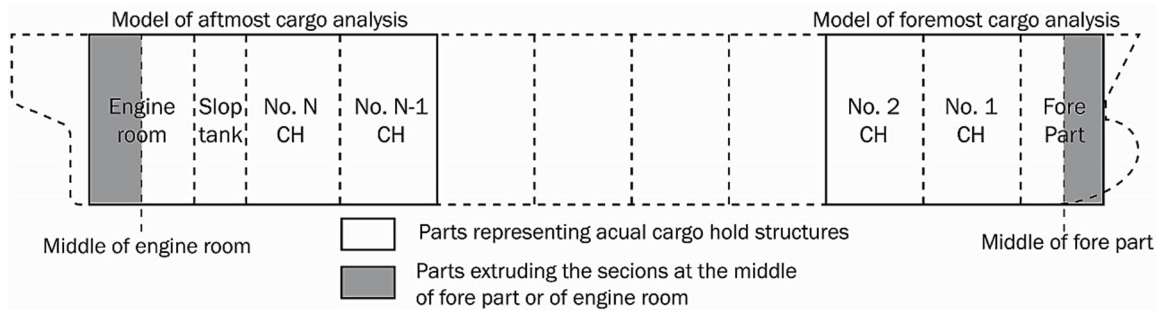
#### 3.4.2.4 Vertical extent:

The full depth of the ship is to be modelled including all primary and secondary members above the upper deck, trunks, forecastle and/or cargo hatch coaming, if any. The superstructure or deck house in way of machinery space and the bulwark are not required to be included in the model.

#### 3.4.2.5 Hull form modelling:

(a) In general, the finite element model is to represent the geometry of hull form. In the mid-ship cargo hold region, the finite element model may be prismatic provided the mid-hold has a prismatic shape.

- (b) The foremost cargo hold model, the hull form forwards of the transverse section at the middle of the fore part up to the model end as defined in 3.4.2.2 may be modelled with a simplified geometry. The transverse section at the middle of the fore part up to the model end may be extruded out to the fore model end, as shown in *Figure 3.4.2*.
- (c) The aft most cargo hold model, the hull form aft of the middle of the machinery space may be modelled with simplified geometry. The section at the middle of the machinery space may be extruded out to its aft bulkhead, as shown in *Figure 3.4.2*.
- (d) When the hull form is modelled by extrusion, the geometrical properties of the transverse section located at the middle of the considered space (fore and machinery space) are copied along the simplified model. The transverse web frames are to be considered along the extruded part with the same properties as the ones in the fore part or in the machinery spaces.



**Figure 3.4.2: Hull form simplification for foremost and aft most cargo hold**

### 3.4.3. Finite element types used

3.4.3.1 Plates are to be modelled using shell element and stiffeners are to be modelled as beam elements having axial, torsional, bi-directional shear and bending stiffness. The eccentricity of the neutral axis is to be modelled.

3.4.3.2 Stiffeners, face plates of primary supporting members and brackets are to be modelled using rod or beam elements.

### 3.4.4 Modelling aspects

#### 3.4.4.1 Mesh

The shell element mesh is to follow the stiffening system as far as practicable, hence representing the actual plates between stiffeners ( $s \times s$ , where  $s$  is the stiffener spacing). In general, the shell element mesh is to satisfy the following requirements:

- One element between every longitudinal stiffener (*Figure 3.4.4(a)*). Longitudinally, the element length is not to be greater than 2 longitudinal spaces with a minimum of three elements between primary supporting members.
- One element between every stiffener on transverse bulkheads, (*Figure 3.4.4(b)*).
- One element between every web stiffener on transverse and vertical web frames, cross ties and stringers (*Figure 3.4.4(a)* and *Figure 3.4.4(c)*).

- At least 3 elements over the depth of double bottom girders, floors, transverse web frames, vertical web frames and horizontal stringers on transverse bulkheads. For cross ties, deck transverse and horizontal stringers on transverse wash bulkheads and longitudinal bulkheads with a smaller web depth, modelling using 2 elements over the depth is acceptable provided that there at least 1 element between every web stiffener. For a single skin ships, 1 element over the depth of side web frames is acceptable. The mesh size of adjacent structure is to be adjusted accordingly.
- The mesh size of hopper tank web frames and topside web frames is to be fine enough to represent the shape of the web ring opening, as shown in *Figure 3.4.4(a)*
- The curvature of free edge on large brackets of primary supporting members is to be modelled to avoid unrealistic high stress due to geometry discontinuities. In general, a mesh size equal to the stiffener spacing is acceptable. The bracket toe may be terminated at the nearest nodal point to provided that the modelled length of bracket arm does not exceed the actual arm length. The bracket flange is not be connected to the plating, as shown in *Figure 3.4.4(d)*. The modelling of the tapering part of the flange is to be in accordance with *Section 3, [3.4.4.7]*. An example of acceptable mesh is shown in *Figure 3.4.4(d)*. Finer mesh is to be used for determination of detailed stress at the bracket toe, as given in *Section 4*.

#### 3.4.4.2 Aspect ratio

The aspect ratios of the shell elements are in general not to exceed 3. The use of triangular elements is to be kept minimum. Where possible, aspect ratio of shell elements in areas where there are likely high stresses or high stress gradients, is to be kept close to 1.

#### 3.4.4.3 Finer mesh

Where the geometry cannot be adequately represented in the cargo hold model and the stress exceeds the cargo hold mesh allowable stress criteria, a finer mesh may be used for such geometry. The mesh size required for such analysis can be governed by the geometry. In such cases, the average stress within an area equivalent to that specified in *Section 3, [3.4.4]* is to comply with the requirements given in *Section 3, [3.9.3]*.

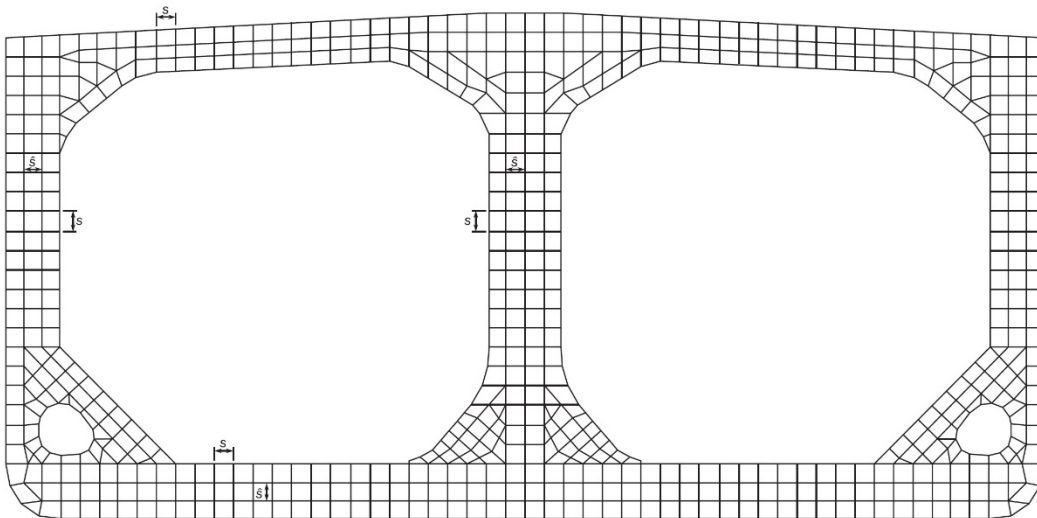




Figure 3.4.4 (a): Typical finite element mesh on web frame

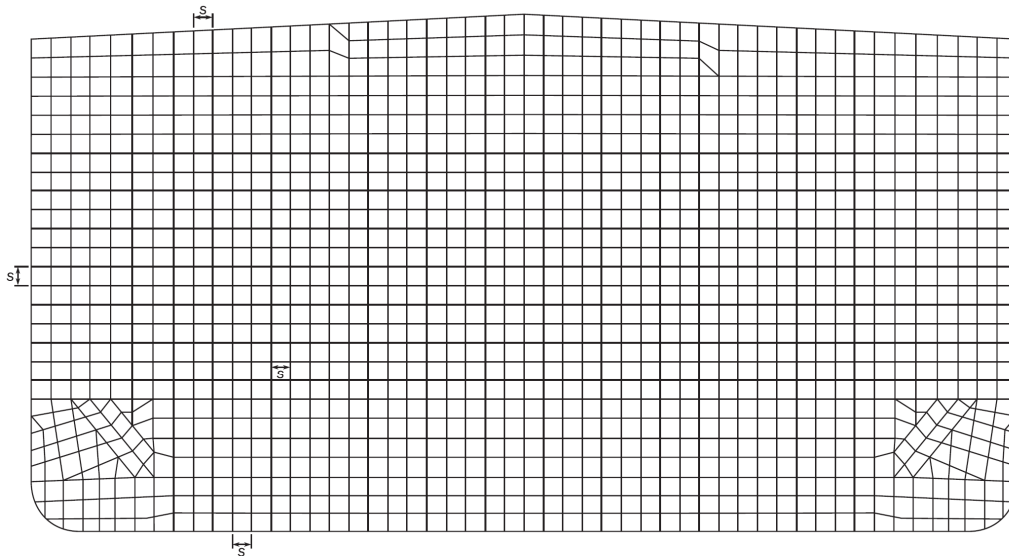


Figure 3.4.4 (b): Typical finite element mesh on transverse bulkhead

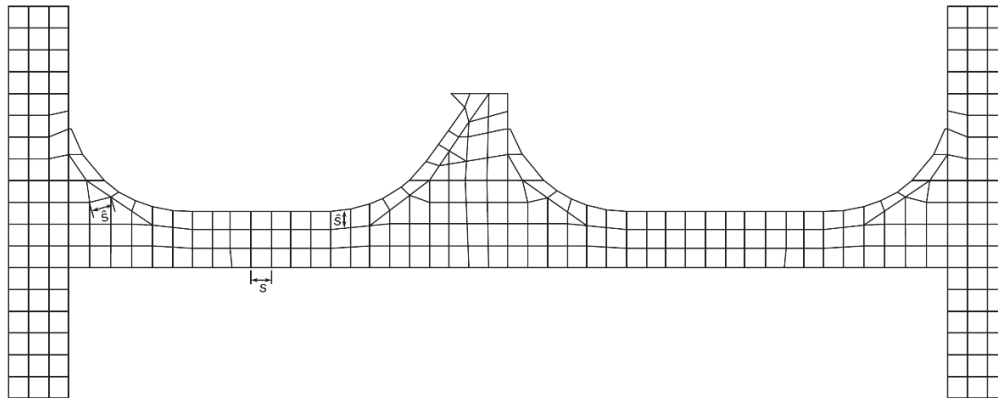
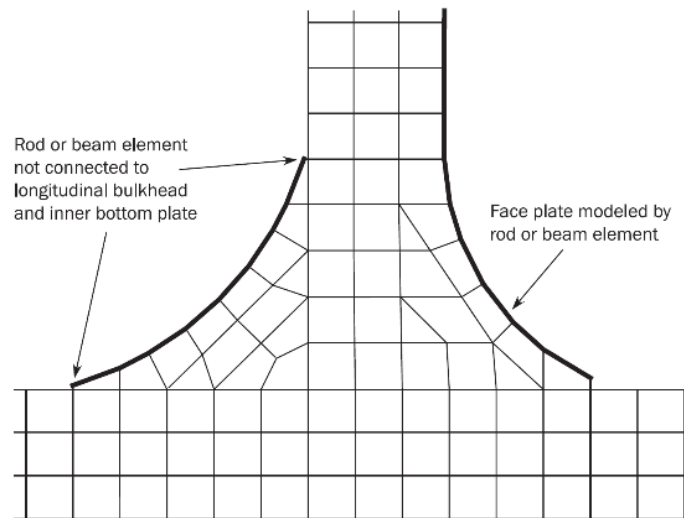


Figure 3.4.4 (c): Typical finite element mesh on horizontal transverse stringer on transverse bulkhead



**Figure 3.4.4 (d): Typical finite element mesh on transverse web frame main bracket**

#### 3.4.4.4 Corrugated bulkheads

Diaphragms in the stools, supporting structure of corrugated bulkheads and internal longitudinal and vertical stiffeners on the stool plating are to be included in the model. Modelling is to be carried out as follows:

- The corrugation is to be modelled with its geometric shape.
- The mesh on the flange and web of the corrugation is in general to follow the stiffener spacing inside the bulkhead stool.
- The mesh on longitudinal corrugated bulkhead is to follow longitudinal positions of transverse web frames, where the corrections to hull girder vertical shear forces are applied in accordance with *Section 3*, [3.8.3.7].
- The aspect ratios of the mesh in the corrugation is not to exceed 2 with minimum of 2 elements for the flange breadth and web height.
- Where difficulty occurs in matching the mesh on the corrugations directly with the mesh on the stool, it is acceptable to adjust the mesh on the stool in way of the corrugations.
- For a corrugated bulkhead with and upper stool and/or lower stool, it may be necessary to adjust the geometry in the model. The adjustment is to be made such that the shape and position of the corrugations and primary supporting members are retained. Hence, the adjustment is to be made on stiffeners and plate seams if necessary.
- When a corrugated bulkhead is subjected to liquid cargo or ballast, dummy rod elements with a cross sectional area of  $1 \text{ mm}^2$  are to be modelled at the corrugation knuckle between the flange and the web. Dummy rod elements are to be used as minimum at the two corrugation knuckles closet to the intersection between:

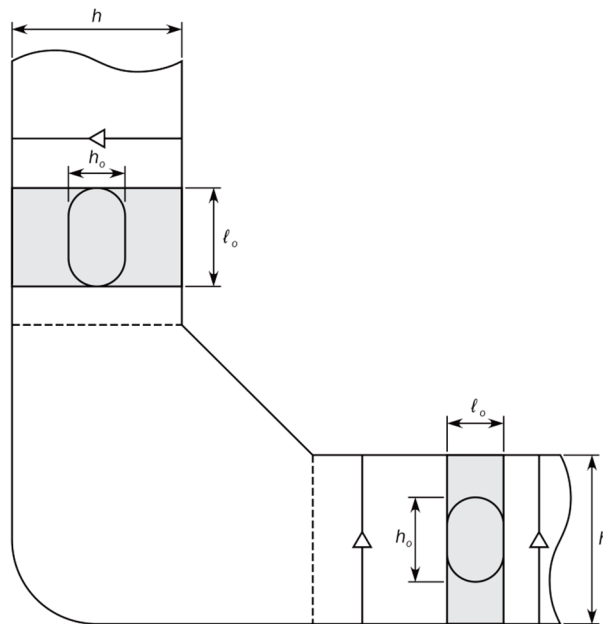
- Transverse and longitudinal bulkheads
  - Transverse bulkhead and inner hull
  - Transverse bulkhead and side shell
- Manholes in diaphragms are to be modelled according to Section 3, [3.4.4.5]

3.4.4.5 Openings

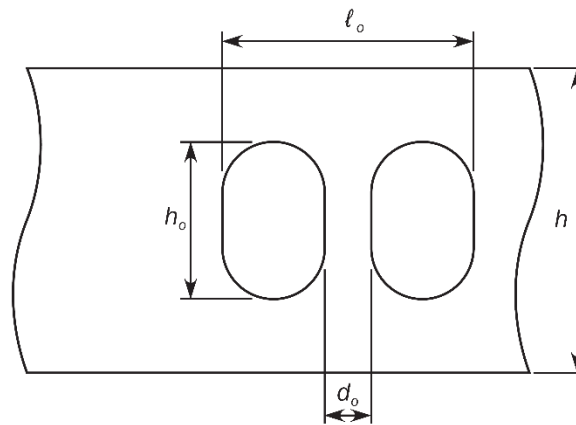
- (a) Methods of representing openings and manholes in webs of primary supporting members are to be in accordance with *Table 3.4.4*. Regardless of size, manholes are to be modelled.
- (b) For openings of about manhole size it is sufficient to delete element/s, with sufficient length and height (between 70% and 150%) of the actual opening. The FE-mesh is to be arranged to accommodate the opening size as far as practical. For larger openings with length and height of at least of two elements (of size of stiffener spacing, *s*) are to be modelled as much as practical with the applied mesh size, see *Figure 3.4.4 (e)* and *Figure 3.4.4 (f)*.

**Table 3.4.4: Representation of openings in primary supporting member webs**

Criteria	Modelling Decision	Analysis
$h_o/h < 0.5$ and $g_o < 2.0$	Openings need not be modelled	To be evaluated by the screening procedure as indicated in <i>Section 4, [4.5]</i>
Manholes	The geometry of the opening is to be modelled by removing the adequate elements	To be evaluated by the screening procedure as indicated in <i>Section 4, [4.5]</i>
$h_o/h > 0.5$ and $g_o > 2.0$	The geometry of the opening is to be modelled	To be evaluated by fine mesh as indicated in <i>Section 4, [4.2]</i>
where:		
$g_o = \left( 1 + \frac{l_o^2}{2.6(h - h_o)^2} \right)$		
$l_o$	: Length of opening parallel to primary supporting member web direction [m], see <i>Figure 3.4.4 (e)</i> . For sequential openings where the distance, <i>d</i> between openings is less than $0.25 h$ , the length $h_o$ is to be taken as the length across openings as shown in <i>Figure 3.4.4 (f)</i> .	
$h_o$	: Height of opening parallel to depth of web [m], refer <i>Figure 3.4.4 (e)</i> and <i>Figure 3.4.4 (f)</i>	
$h$	: Height of web of PSM in way of opening [m], see <i>Figure 3.4.4 (e)</i> and <i>Figure 3.4.4 (f)</i>	



**Figure 3.4.4 (e): Opening in web**



**Figure 3.4.4 (f): Length  $l_o$  for sequential openings with  $d_o < h/4$**

#### 3.4.4.6 Stiffeners

Non-continuous stiffeners are to be modelled as continuous stiffeners, i.e. the height web reduction in way of snip ends are not to be modelled.

Web stiffeners of primary supporting members are to be modelled. Where these stiffeners are not in line with primary FE mesh, it is sufficient to place the line element along the nearby nodal points provided that the adjusted distance does not exceed 0.2 times the stiffener spacing under consideration. The stress and buckling utilization factors obtained need not be corrected for the adjustment. Buckling of stiffeners on large brackets, deck transverses and stringers parallel to the flange are to be modelled. These stiffeners on large brackets, deck transverse and stringers parallel to the flange are to be modelled. These stiffeners may be modelling using rod elements.

#### 3.4.4.7 Face plate of primary supporting member

The effective cross-sectional area at the curved part of the face plate of primary supporting members and brackets is to be calculated in accordance with IRS Rules for Bulk Carrier and Oil Tankers, *Chapter 3, Section 7*. The cross-sectional area of a rod or beam element representing the tapering part of the face plate is to be based on the average cross-sectional area of the face plate in way of the element length.

### 3.5 Boundary conditions

#### 3.5.1 General

3.5.1.1 All boundary conditions described in this section are in accordance with the global coordinate system defined in *Section 1, [1.4]*.

#### 3.5.2 Application

3.5.2.1 All boundary conditions described in this section are applicable to cargo hold finite element model analyses in cargo hold region as defined in *[3.2]*.

#### 3.5.3 Boundary conditions

3.5.3.1 The boundary conditions consist of the rigid links at model ends, point constraints and end-beams. The rigid links connect the nodes on the longitudinal members at the model ends to an independent point at neutral axis in centreline. The boundary conditions to be applied at the ends of the cargo hold FE model, except for the foremost cargo hold, are given in *Table 3.5.3 (a)*. For the foremost cargo hold analysis, the boundary conditions to be applied at the ends of the cargo hold FE model are given in *Table 3.5.3 (b)*.

Table 3.5.3 (a): Supporting constraints at model ends except foremost cargo hold models						
Location	Translation			Rotation		
	$\delta_x$	$\delta_y$	$\delta_z$	$\theta_x$	$\theta_y$	$\theta_z$
Aft end						
Independent point	-	Fix	Fix	$M_{T-end}$	-	-
Cross-section	-	Rigid link	Rigid link	Rigid link	-	-
	End beam, refer <i>Section 3, [3.5.4]</i>					
Fore end						
Independent point	-	Fix	Fix	Fix	-	-
Intersection of centreline and inner bottom <sup>3</sup>	Fix	-	-	-	-	-
Cross-section	Fix	Rigid link	Rigid link	Rigid link	-	-
	End beam, refer <i>Section 3, [3.5.4]</i>					
<b>Note 1:</b> [-] means no constraint applied (free)						
<b>Note 2:</b> See <i>Figure 3.5.3</i> .						
<b>Note 3:</b> Fixation point can be made on continuous structure at centreline other than independent point (e.g. outer bottom at centreline or longitudinal bulkhead at centreline)						

Table 3.4.3 (b): Supporting constraints at model ends of the foremost cargo hold model						
Location	Translation			Rotation		
	$\delta_x$	$\delta_y$	$\delta_z$	$\theta_x$	$\theta_y$	$\theta_z$
Aft end						
Independent point	-	Fix	Fix	Fix	-	-
Intersection of centreline and inner bottom	Fix	-	-	-	-	-
Cross-section	-	Rigid link	Rigid link	Rigid link	-	-
	End beam, Refer Section 3, [3.5.4]					
Fore end						
Independent point	-	Fix	Fix	Fix	-	-
Cross-section	Fix	Rigid link	Rigid link	Rigid link	-	-
	End beam, Refer Section 3, [3.5.4]					
<p><b>Note 1:</b> [-] means no constraint applied (free)</p> <p><b>Note 2:</b> See Figure 3.5.3.</p> <p><b>Note 3:</b> Boundary constraints in fore end are to be located at the most forward reinforced ring or web frame which remains continuous from the base line to the strength deck.</p> <p><b>Note 4:</b> Fixation point can be made on continuous structure at centreline other than independent point (e.g. outer bottom at centreline or longitudinal bulkhead at centreline)</p>						

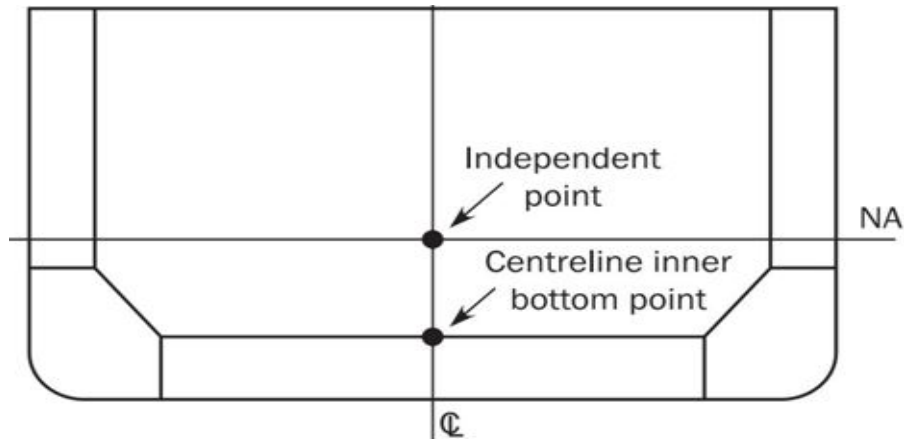
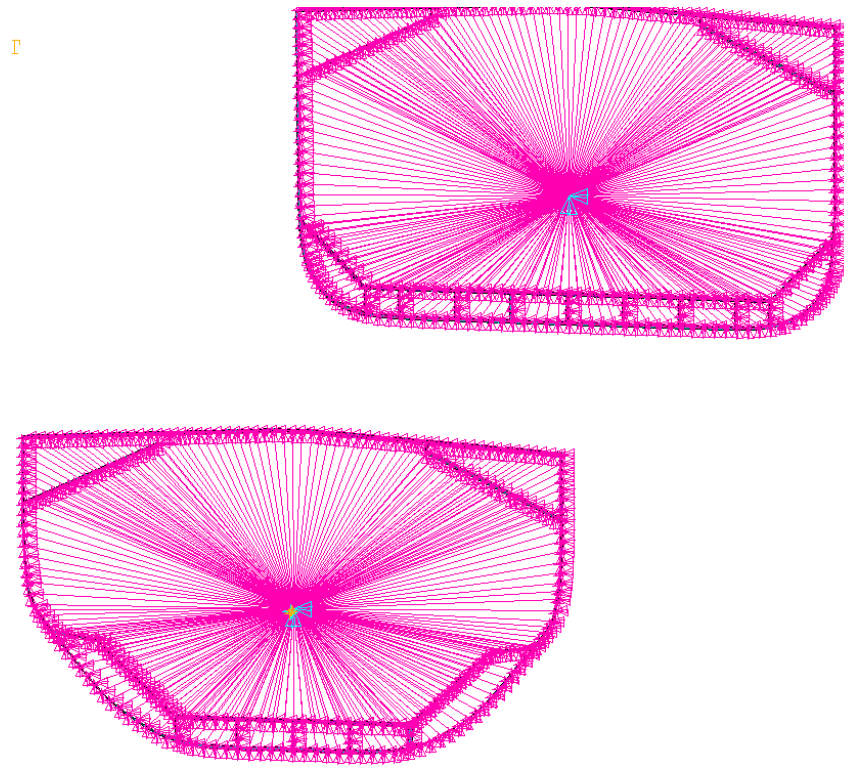


Figure 3.5.3: Boundary conditions applied at the model end sections



**Figure 3.5.4: End constraint beams modelled for a bulk carrier**

### 3.5.4 End constraint beams

3.5.4.1 End constraint beams are to be modelled at both end sections of the model along all longitudinally continuous structural members and along the cross-deck plating. A typical example of end beams modelled at each end of a bulk carrier is shown in *Figure 3.5.4*.

3.5.4.2 The properties of beams are calculated at fore and after sections separately and all beams at each end section have identical properties as follows:

- Net moment of inertia:  $I_{yy} = I_{zz} = I_{xx} (J) = 1/25$  of the vertical hull girder moment of inertia of fore/aft end cross sections based on the net FE model.
- Net cross-sectional area:  $A_y = A_z = 1/80$  of the fore/aft end cross sectional areas based on the net FE model.

where,

$I_{yy}$  : Net moment of inertia bout the local beam Y axis [m<sup>4</sup>]

$I_{zz}$  : Net moment of inertia bout the local beam Z axis [m<sup>4</sup>]

---

$I_{xx}$ (J)	:	Torsional inertia [m <sup>4</sup> ]
$A_y$	:	Shear area in local beam in Y direction [m <sup>2</sup> ]
$A_z$	:	Shear area in local beam in Z direction [m <sup>2</sup> ]

### 3.6 Loads and FE load combinations

#### 3.6.1 Design loads

3.6.1.1 Design loads are linked with the design conditions and/or operating conditions related to hull structural strength, referenced over the entire service life of a ship. Design load scenario for strength assessment (composed of a Static load case (S) or a Static + Dynamic (S+D) load case) that imposes the most onerous loads regimes is to be investigated; where the static and dynamic loads are dependent on the loading condition being considered.

3.6.1.2 Design loads for cargo hold analysis are as provided in IRS Rules *Part 3, Chapter 4*. For specific type of ship, IRS Rules *Part 5* is to be referred.

#### 3.6.2 Design load combinations

##### 3.6.2.1 FE load combination

An FE load combination is defined as a loading pattern, a draught, a still water bending and shear force, associated with a given loading condition. Each load combination requires the application of the structural weight, internal and external pressures and hull girder loads. For seagoing condition, both static and dynamic load components are applied. A typical FE load combination sample tabulation is given in Table 3.6.2 below. FE load combinations can be decided based on the following components:

(a) Loading pattern

Arrangement of internal loads in FE model configures the various loading pattern. The various patterns are to be checked to get the most onerous one which induced the maximum loads. The severe loading condition is considered for the analysis.

(b) Draught

Draught and loading pattern is to be combined in such a way that the net loads acting on the individual structures are maximized.

(c) Percentage of permissible still water shear force and bending moment

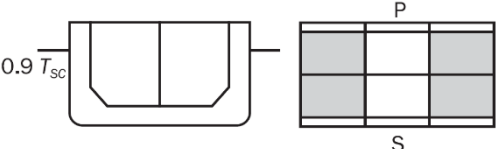
It is the percentage of permissible still water shear force,  $Q_{SF}$  and still water bending moment,  $M_{SW}$  that is considered for that particular loading pattern and draught. In general, it is taken as 100%.

(d) Loading condition



The dynamic loads are to be determined as per *Part 3, Chapter 5*. A dynamic load consists of internal, external pressure and hull girder loads. For cargo hold structural strength analysis, the design loads specified in the Rules are to be used for the considered ship types and considered cargo hold regions.

Where the loading conditions provided by designer are not covered by FE load combination in the Rules, additional loading conditions are to be examined according to the procedure given in this section.

Table 3.5.2: FE load combination tabulation sample				
No.	Loading Pattern	Still Water Loads		Loading Condition
		Draught	Percentage of permissible SWBM/SWSF	
Harbour conditions (S)				
1.	a	b	c	d
2.				
Seagoing conditions (S+D)				
	a	b	c	d
a, b, c, d as defined above				

### 3.7 Load application

#### 3.7.1 General

##### 3.7.1.1 Sign convention

Unless otherwise mentioned in this Section, the sign of moments and shear force is to be in accordance with the sign convention defined in *Part 3, Chapter 5, Section 2 [2.1.1]* of the Rules.

##### 3.7.1.2 Hull structural weight:

Effect of the weight of hull structure is to be included in static loads, but is not to be included in dynamic loads. If not specified, the density of steel is to be taken as 7.85 [t/m<sup>3</sup>].

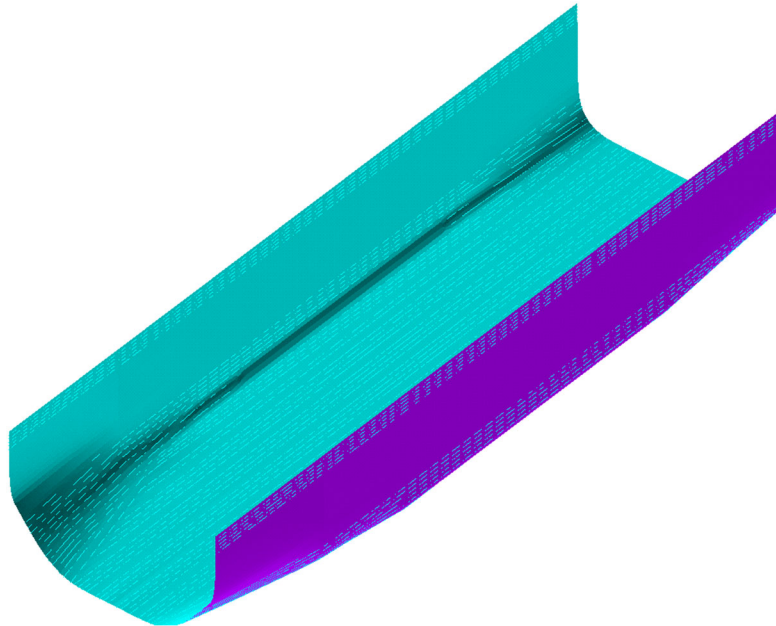
#### 3.7.2 External and internal loads

##### 3.7.2.1 Pressure application of FE element

Constant pressure, calculated at the element's centroid, is applied to the shell element of the loaded surfaces, e.g. outer shell and deck for external pressure and tank/hold boundaries for internal pressure. Alternately, pressure can be calculated at element nodes applying linear pressure distribution within elements. A typical illustration of pressure application on the outer hull portion is given in *Figures 3.7.2 (a)* and *Figure 3.7.2 (b)*.

#### 3.7.2.2 External pressure

External pressure is to be calculated in accordance with *Part 3, Chapter 4, Section 3* of the Rules. External pressures include static sea pressure, wave pressure and green sea pressure. The forces applied on the hatch cover by the green sea pressure are to be distributed along the top of the corresponding hatch coamings.



**Figure 3.7.2 (a): Illustration of pressure application on the outer hull of a 3 cargo hold FE model**

#### 3.7.2.3 Internal pressure

Internal pressures are to be calculated in accordance with *Part 3, Chapter 4, Section 3* of the Rules and in case specific type of vessel *Part 5* is to be referred. Internal pressures include static dry and liquid cargo, ballast and other liquid pressure, setting pressure on relief valve and dynamic pressure of dry and liquid cargo, ballast and other liquid pressure due to accelerations.

3.7.2.4 Any specific loads other than those listed above are to be taken as per the provisions given in *Part 5* and IRS Guidelines *IRS-G-DES-06*.

### 3.8 Hull girder loads

#### 3.8.1 General

As the three holds FE model (which is simply supported at both ends, in which the required local loads (i.e. static and dynamic hold pressure, static sea and dynamic wave pressure and structural

weight) are applied) represents only a part of the actual ship, the local loads applied to the model will depict only a semi-global effect. These semi-global hull girder loads may not have reached the intended target values of hull girder loads specified in *Part 3, Chapter 5, Section 2* of the Rules. Hence, hull girder loads need to be adjusted by the application of additional forces and moments in order to properly represent the actual loading states. The hull girder loads in each loading condition are a combination of still water hull girder loads and wave induced hull girder loads as specified in *Part 3, Chapter 5 Section 2* of the Rules. These target values of hull girder components that needs to be separately adjusted are namely:

- 3.8.2 (a) Target hull girder vertical bending moment
- 3.8.2 (b) Target hull girder vertical shear force

### 3.8.2 Hull girder targets

#### (a) Target hull girder vertical bending moment

The target hull girder vertical bending moment,  $M_{v-targ}$  [kN-m] at a longitudinal position for a given FE load combination is taken as:

$$M_{v-targ} = M_{sw} + M_{wv}$$

where:

$M_{sw}$  Permissible still water bending moments at the considered longitudinal position for seagoing and harbour conditions as defined in the rules, *Chapter 5, Section 2* and respectively.  $M_{sw}$  is either in sagging or in hogging condition.

$M_{wv}$  Vertical wave bending moment [kN-m], for the loading condition under consideration, calculated in accordance with the IRS Rules, *Chapter 5, Section 2*.

The values of  $M_{v-targ}$  are taken as:

- Mid-ship cargo hold region: the maximum hull girder bending moment within the mid-hold(s) of the model for given loading condition as defined in *Chapter 5, Section 2*.
- Outside mid-ship cargo hold region: the values of all web frame and transverse bulkhead positions of the FE model under consideration.

#### (b) Target hull girder vertical shear force

The target hull girder vertical shear force at the aft and forward transverse bulkheads of the mid-hold,  $Q_{targ-aft}$  and  $Q_{targ-fwd}$  [kN] for a given FE load combination is taken as:

$$Q_{fwd} \geq Q_{aft}$$

$$Q_{targ-aft} = Q_{sw-neg} - \Delta Q_{swa} + f_{\beta} |C_{QW}| Q_{wv-neg}$$

$$Q_{targ-fwd} = Q_{sw-pos} + \Delta Q_{swf} + f_{\beta} |C_{QW}| Q_{wv-pos}$$

$$Q_{fwd} < Q_{aft}$$

$$Q_{\text{targ-aft}} = Q_{\text{sw-pos}} + \Delta Q_{\text{swa}} + f_{\beta} |C_{\text{QW}}| Q_{\text{wv-pos}}$$

$$Q_{\text{targ-fwd}} = Q_{\text{sw-neg}} - \Delta Q_{\text{swf}} + f_{\beta} |C_{\text{QW}}| Q_{\text{wv-neg}}$$

where:

$Q_{\text{fwd}}, Q_{\text{aft}}$  : Vertical shear forces [kN] due to the local loads respectively at the forward and aft bulkhead position of the mid-hold, as defined in *Section 3, [3.8.3.6]*.

$Q_{\text{sw-pos}}, Q_{\text{sw-neg}}$  : Positive and negative permissible still water shear forces [kN] at any longitudinal position for seagoing and harbour conditions as defined in the *Part 3, Chapter 5, Section 2*.

$\Delta Q_{\text{mdf}}$  : Shear force correction at the considered transverse section for the considered cargo hold and is calculated as:

$$\Delta Q_{\text{mdf}} = C_d \alpha \left( \frac{M}{B_H l_H} - \rho T_{\text{LC-mh}} \right)$$

$C_d$  : Distribution coefficient taken as:

- $C_d = -1$  at the aft end of the considered cargo hold except for aftmost cargo hold.
- $C_d = 1$  at the fore end of the considered cargo hold except for foremost cargo hold.
- $C_d = 0$  at mid-length of the cargo hold.
- $C_d = 0$  at the aft bulkhead of the aftmost cargo hold.
- $C_d = 0$  at the fore bulkhead of the foremost cargo hold.
- $C_d$ : Linearly distributed at other locations.

$\alpha$  : Coefficient taken as:

$$\alpha = g \frac{l_0 b_0}{2 + \varphi \frac{l_0}{b_0}}$$

$M$  : Mass, in t, in the hold in way of the considered transverse section for the considered loading condition.  $M$  is to include the mass of ballast water and fuel oil located directly below the flat portion of the inner bottom, if any, excluding the portion under the bulkhead stool.

$B_H$  : Breadth of the cargo hold, in m, measured at mid-length of the cargo hold and at the mid height between the top of hopper tank and the bottom of topside tank [m] as per Figure 3.8.2.

$l_H$  : Length of the cargo hold [m] at the centreline between the transverse bulkheads. This is to be measured to the mid-depth of the corrugated bulkhead(s) if fitted [m] as per Figure 3.8.2.

$l_0, b_0$  : Length and breadth, respectively [m] of the flat portion of the double bottom in way of the hold considered;  $b_0$  is to be measured on the hull transverse section at the middle of the hold.

$$\varphi = 1.38 + 1.55 \frac{l_0}{b_0}$$

$T_{LC-mh}$  : Draught, in m, measured vertically on the hull transverse section at the middle of the hold considered, from the moulded baseline to the waterline in the loading condition considered.

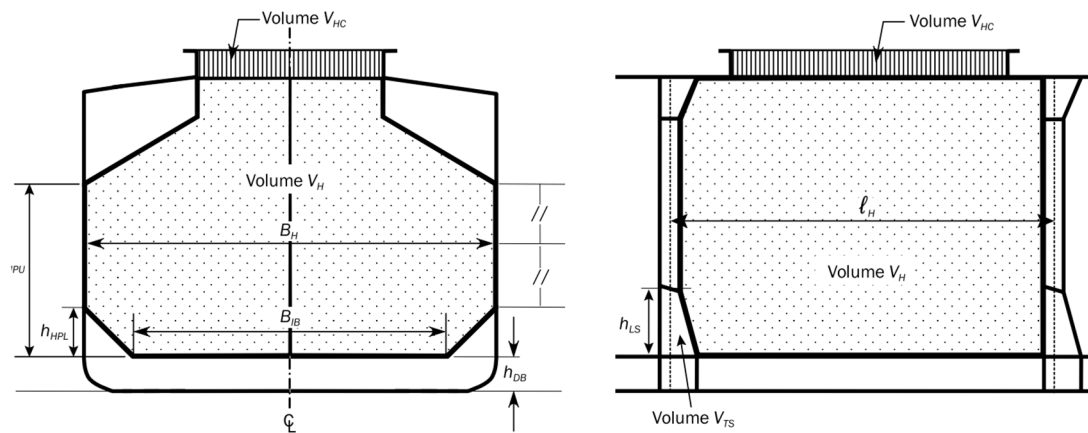


Figure 3.8.2: Definition of cargo hold parameters for bulk carrier

$\Delta Q_{swf}$  : Shear force correction [kN] for the considered FE loading pattern at the forward bulkhead taken as minimum of the absolute values of  $\Delta Q_{mdf}$ , calculated at the forward bulkhead for the mid hold and the aft bulkhead of the forward cargo hold taken as:

- For ships where shear force correction  $\Delta Q_{mdf}$  is required (E.g. for bulk carriers) should be taken as:

$$\Delta Q_{swf} = \text{Min} (|\Delta Q_{mdf}|_{mid}, |\Delta Q_{mdf}|_{fwd})$$

- Otherwise:

$$\Delta Q_{swf} = 0$$

$\Delta Q_{swa}$  : Shear force correction [kN] for the considered FE loading pattern at the aft bulkhead taken as minimum of the absolute values of  $\Delta Q_{mdf}$ , calculated at the aft bulkhead for the mid hold and the forward bulkhead of the aft cargo hold taken as:

- For ships where shear force correction  $\Delta Q_{\text{mdf}}$  is required should be taken as:

$$\Delta Q_{\text{swa}} = \text{Min} (|\Delta Q_{\text{mdf}}|_{\text{mid}}, |\Delta Q_{\text{mdf}}|_{\text{aft}})$$

- Otherwise:

$$\Delta Q_{\text{swa}} = 0$$

$f_{\beta}$  : Wave heading factor = 1.

$C_{\text{QW}}$  : Load combination factor for vertical wave shear force = 1.

$Q_{\text{wv-pos}}, Q_{\text{wv-neg}}$  : Positive and negative vertical wave shear force [kN] as defined in *Chapter 5, Section 2*.

### 3.8.3 Procedure to adjust hull girder shear force and bending moments

#### 3.8.3.1 General

- The procedure provided here describes how to adjust the hull girder horizontal bending moment, vertical force and vertical bending moment distribution on the three cargo hold FE model to achieve the required target values at required locations. The hull girder load target values are specified in *Section 3, [3.8.2]*.
- The target locations for the hull girder shear force are at the transverse bulkheads of the mid-hold of the FE model. It should be ensured that the final adjusted hull girder shear force at the target location does not exceed the target hull girder shear force.
- The target location for hull girder bending moment is, in general, located at the centre of the mid-hold of the FE model. If the maximum value of bending moment is not located at the centre of the mid-hold, the final adjusted maximum bending moment should be located within the mid-hold and the value is to not exceed the target hull girder bending moment.

#### 3.8.3.2 Local load distribution

The following local loads should be applied on the FE model for the calculation of hull girder shear and bending moments:

- Ship structural steel weight distribution over the length of the cargo hold model (static loads).
- Weight of cargo and ballast (static loads).
- Static sea pressure, dynamic wave pressure and, where applicable, green sea load.
- Dynamic cargo and ballast loads.

With the above local loads applied to the FE model, the FE nodal forces are obtained through FE loading procedure. The 3D nodal forces will then be lumped to each longitudinal station to generate the one-dimensional local load distribution. The longitudinal stations are located at transverse bulkheads/frames and typical longitudinal FE model nodal locations in between the frames according to the cargo hold model mesh size requirement. Any intermediate nodes created for modelling structural details are not treated as the longitudinal stations for the purpose of local load distribution. The nodal forces within half of forward and half of afterword of longitudinal station spacing are lumped to that station. The lumping process will be done for

vertical and horizontal nodal forces separately to obtain the lumped vertical and horizontal local loads, ' $f_{vi}$ ' and ' $f_{hi}$ ', at the longitudinal station 'i'.

### 3.8.3.3 Hull girder forces and bending moment due to local loads:

With the local load distribution, the hull girder load longitudinal distributions are obtained by assuming the model is simply supported at model ends. The reaction forces at both ends of the model and longitudinal distributions of hull girder shear forces, and bending moments induced by local loads at any longitudinal station, are determined by the following formulae:

$$R_{V\text{-fore}} = - \frac{\sum_i (X_i - X_{\text{aft}}) f_{vi}}{X_{\text{fore}} - X_{\text{aft}}} \qquad R_{V\text{-aft}} = \sum_i f_{vi} + R_{V\text{-fore}}$$

$$R_{H\text{-fore}} = \frac{\sum_i (X_i - X_{\text{aft}}) f_{hi}}{X_{\text{fore}} - X_{\text{aft}}} \qquad R_{H\text{-aft}} = - \sum_i f_{hi} + R_{H\text{-fore}}$$

$$F_i = \sum_i f_{li}$$

$$Q_{V\text{-FEM}}(X_j) = R_{V\text{-aft}} - \sum_i f_{vi} \qquad \text{When } X_i < X_j$$

$$Q_{H\text{-FEM}}(X_j) = R_{H\text{-aft}} - \sum_i f_{hi} \qquad \text{When } X_i < X_j$$

$$M_{V\text{-FEM}}(X_j) = (X_j - X_{\text{aft}})R_{V\text{-aft}} - \sum_i (X_j - X_{\text{aft}})f_{vi} \qquad \text{When } X_i < X_j$$

$$M_{H\text{-FEM}}(X_j) = (X_j - X_{\text{aft}})R_{H\text{-aft}} - \sum_i (X_j - X_i)f_{vi} \qquad \text{When } X_i < X_j$$

where,

- $R_{V\text{-fore}}, R_{V\text{-aft}}, R_{H\text{-fore}}, R_{H\text{-aft}}$  : Vertical and horizontal reaction at the aft and fore end [kN]
- $X_{\text{aft}}$  : X-coordinate of the aft end support [m].
- $X_{\text{fore}}$  : X-coordinate of the fore end support [m].
- $f_{vi}$  : Lumped vertical local load at longitudinal station i as defined in [3.8.3.2] [kN].
- $f_{hi}$  : Lumped horizontal local load at longitudinal station i as defined in [3.8.3.2] [kN].
- $F_i$  : Total net longitudinal force of the model [kN]
- $f_{li}$  : Lumped longitudinal local load at longitudinal station i as defined in [3.8.3.2] [kN].
- $X_j$  : X-coordinate [m] of considered longitudinal station j.
- $X_i$  : X-coordinate [m] of longitudinal station i.

$Q_{V-FEM}(X_j)$	:	Vertical and horizontal shear forces [kN] and bending moments [kN-m], at longitudinal station $X_j$ created by the local loads applied on the FE model. The sign convention for reaction forces is that a positive bending moment creates a positive shear force.
$Q_{H-FEM}(X_j)$		
$M_{V-FEM}(X_j)$		
$M_{H-FEM}(X_j)$		

### 3.8.3.4 Longitudinal unbalanced forces

In case the total net longitudinal force of the finite element mode,  $F_i$ , not equal to zero, the counter longitudinal force,  $(F_x)_j$ , is to be applied at one end of the model, where the translation on X-direction,  $\delta_x$ , is fixed, by distributing longitudinal axial nodal forces to all hull girder bending effective longitudinal elements, as follows:

$$(F_x)_j = \frac{F_i}{A_{x-n50}} \frac{A_{j-n50}}{n_j}$$

where,

$(F_x)_j$	: Axial force applied to a node of the j-th element [kN].
$F_i$	: Total net longitudinal force of the model, as defined in [3.8.3.2] [kN]
$A_{j-n50}$	: Cross sectional area of the j-th element [m <sup>2</sup> ]
$A_{x-n50}$	: Cross sectional area of fore end section [m <sup>2</sup> ]
	Number of nodal points of j-th element on the cross section, $n_j = 1$
$n_j$	: for beam element, $n_j = 2$ for 4-node shell element.

### 3.8.3.5 Hull girder shear force adjustment procedure

- The following two methods are to be used for the shear force adjustment:
  - a) Method 1 (M1): for shear force adjustment at one bulkhead of the mid-hold as given in [3.8.3.6],
  - b) Method 2 (M2): for shear force adjustment at both bulkheads of the mid-hold as given in [3.8.3.7].
- For the considered FE load combination, the method to be applied is to be selected as follows:
  - a) For maximum shear force load combination (Max SFLC), the Method 1 applies at the bulkhead given in *Table 3.8.3 (a)*, if the shear force after the adjustment with Method 1 at the other bulkhead does not exceed the target value. Otherwise, the method 2 applies.
  - b) For other shear force load combination:
    - The shear force adjustment is not required when the shear forces at both bulkheads are lower or equal to the target values.



- Method 1 applies when the shear force exceeds the target at one bulkhead and the shear force at the other bulkhead after the adjustment with method 1 does not exceed the target value. Otherwise the method 2 applies,
  - Method 2 applies when the shear forces at both bulkheads exceed the target values,
- The “maximum shear force load combinations “are marked as “Max SFLC “in the load combination tables. Where FE load combinations are specified in IRS Rules for specific ships, Refer *Part 5* of the Rules. The “other shear force load combinations “are those which are not the maximum shear force load combinations. They are not marked in the load combination tables.

<b>Table 3.8.3 (a): Mid-hold bulkhead location for SF adjustment</b>				
Design Loading Condition	Bulkhead Location	$M_{wv-LC}$	Condition on $Q_{fwd}$	Mid-hold BHD for SF adjustment
Seagoing Conditions	$X_{b-aft} > 0.5 L$	<0 (sagging)	$Q_{fwd} > Q_{aft}$	Forward
			$Q_{fwd} \leq Q_{aft}$	Aft
		>0 (hogging)	$Q_{fwd} > Q_{aft}$	Aft
			$Q_{fwd} \leq Q_{aft}$	Forward
	$X_{b-fwd} < 0.5 L$	<0 (sagging)	$Q_{fwd} > Q_{aft}$	Aft
			$Q_{fwd} \leq Q_{aft}$	Forward
		>0 (hogging)	$Q_{fwd} > Q_{aft}$	Forward
			$Q_{fwd} \leq Q_{aft}$	Aft
	$X_{b-aft} \leq 0.5 L$ and $X_{b-fwd} \geq 0.5 L$	-	-	[*]
Harbour and testing conditions	Whatever the location	-	-	[*]
<p>[*] No limitation of Mid-hold bulkhead location for shear force adjustment. In this case the shear force can be adjusted to the target either at forward (Fwd) or at aft (Aft) mid hold bulkhead.</p> <p><b>Note:</b> The bulkhead where the shear force adjustment is to be done either at aft or forward bulkhead of mid-hold in accordance with the load arrangements in the tanks and loading condition.</p>				

## 3.8.3.6 Method 1 for vertical shear force adjustment at one bulkhead

- The required adjustments in shear force at following transverse bulkheads of the mid-hold are given by:

a) Aft bulkhead:

$$M_{Y\text{-aft}} = M_{Y\text{-fore}} = \frac{(X_{\text{fore}} - X_{\text{aft}})}{2} (Q_{\text{targ-aft}} - Q_{\text{aft}})$$

b) Forward bulkhead:

$$M_{Y\text{-aft}} = M_{Y\text{-fore}} = \frac{(X_{\text{fore}} - X_{\text{aft}})}{2} (Q_{\text{targ-fwd}} - Q_{\text{fwd}})$$

where,

$M_{Y\text{-aft}}, M_{Y\text{-fore}}$  : Vertical bending moment [kN-m] to be applied at the aft and fore ends in accordance with [3.8.3.10], to enforce the hull girder vertical shear force adjustment as shown in *Table 3.8.3 (b)*. The sign convention is that of the FE model axis.

$Q_{\text{aft}}$  : Vertical shear force [kN] due to local loads at aft bulkhead location of mid-hold,  $X_{b\text{-aft}}$  resulting from the local loads calculated according to [3.8.3.3].

Since the vertical shear force is discontinued at the transverse bulkhead location,  $Q_{\text{aft}}$  is the maximum absolute shear force between the stations located right after and right forward of the aft bulkhead of mid-hold.

$Q_{\text{fwd}}$  : Vertical shear force [kN] due to local loads at the forward bulkhead location of mid-hold,  $X_{b\text{-fwd}}$  resulting from the local loads calculated according to [3.8.3.3].

Since the vertical shear force is discontinued at the transverse bulkhead location,  $Q_{\text{fwd}}$  is the maximum absolute shear force between the stations located right after and right forward of the forward bulkhead of mid-hold.

Table 3.8.3 (b): Vertical shear force adjustment by application of vertical bending moments $M_{Y- aft}$ and $M_{Y- fore}$ for Method 1	
Vertical Shear Force Diagram	Target Position
	Forward Bulkhead
	Aft Bulkhead
<p>— Vertical shear force after adjustment</p> <p>- - - - - Vertical shear force due to local loads</p>	

3.8.3.7 Method 2 for vertical shear force adjustment at both bulkheads

— The required adjustments in shear force at both transverse bulkheads of the mid- hold are to be made by applying:

- a) Vertical bending moments,  $M_{Y- aft}$ ,  $M_{Y- fore}$  at model ends and,

- b) Vertical loads at the transverse frame positions as shown in *Table 3.8.3 (c)* in order to generate vertical shear forces,  $\Delta Q_{\text{aft}}$  and  $\Delta Q_{\text{fwd}}$ , at the transverse bulkhead positions.

*Table 3.8.3 (c)* shows examples of the shear adjustment application due to the vertical bending moments and to vertical loads.

$$M_{Y-\text{aft}} = \frac{X_{\text{fore}} - X_{\text{aft}}}{2} \cdot \frac{Q_{\text{targ-fwd}} - Q_{\text{fwd}} + Q_{\text{targ-aft}} - Q_{\text{aft}}}{2}$$

$$M_{Y-\text{fore}} = M_{Y-\text{aft}}$$

$$\Delta Q_{\text{fwd}} = \frac{Q_{\text{targ-fwd}} - Q_{\text{fwd}} - (Q_{\text{targ-aft}} - Q_{\text{aft}})}{2}$$

$$\Delta Q_{\text{aft}} = -\Delta Q_{\text{fwd}}$$

where,

$M_{Y-\text{aft}}$ ,  $M_{Y-\text{fore}}$  : Vertical bending moment [kN-m] to be applied at the aft and fore ends in accordance with [3.8.3.10], to enforce the hull girder vertical shear force adjustment. The sign convention is that of the FE model axis.

$\Delta Q_{\text{aft}}$  : Adjustment of shear force [kN] at aft bulkhead of mid-hold.

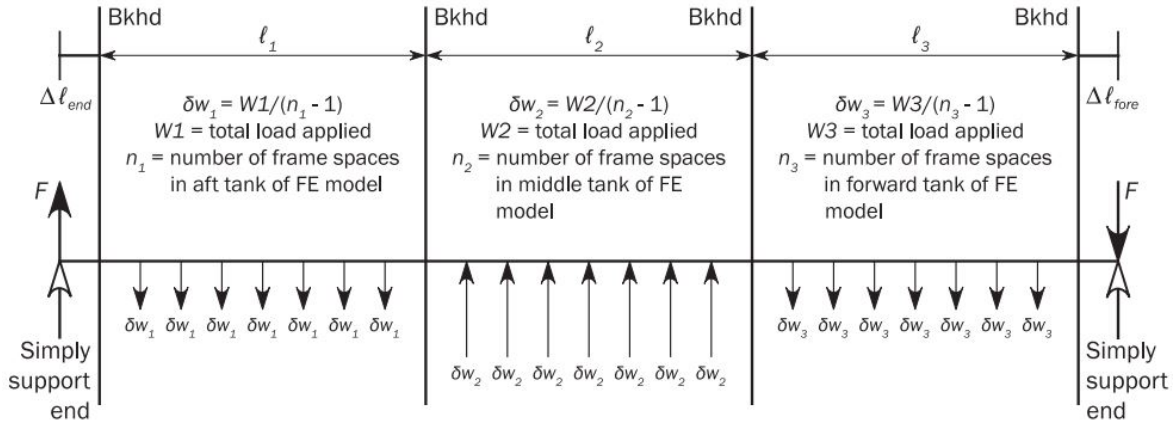
$\Delta Q_{\text{fwd}}$  : Adjustment of shear force [kN] at fore bulkhead of mid-hold.

- The above adjustments in shear forces,  $\Delta Q_{\text{aft}}$  and  $\Delta Q_{\text{fwd}}$ , at the transverse bulkhead positions are to be generated by applying vertical loads at the transverse frame positions as shown in *Table 3.8.3 (c)*. For bulk carriers, the transverse frame positions correspond to the floors. Vertical correction loads are not to be applied to any transverse tight bulkheads, any frames forward of the forward cargo hold and any frames aft of the aft cargo hold of the FE model.
- The vertical loads to be applied to each transverse frame to generate the increase/decrease in shear force at the bulkheads may be calculated as shown in *Table 3.8.3 (c)*. In case of uniform frame spacing, the amount of vertical force to be distributed at each transverse frame may be calculated in accordance with *Table 3.8.3 (d)*

**Table 6.8.3 (c): Target and required shear force adjustment by applying vertical forces**

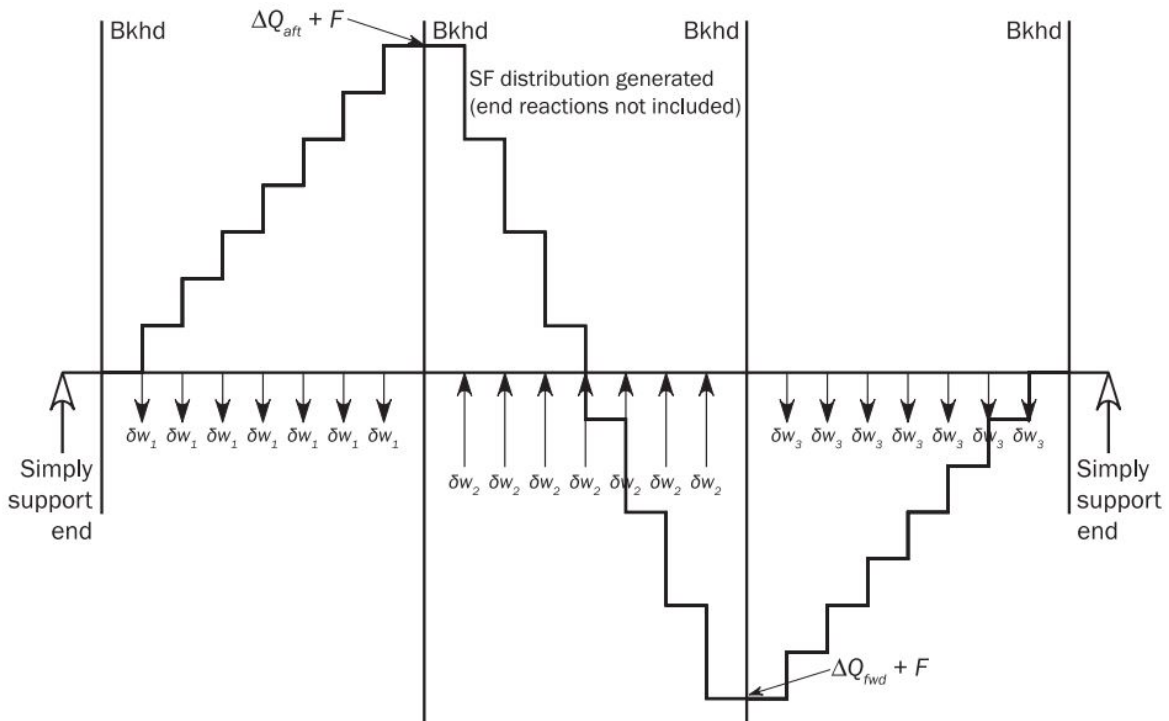
Vertical Shear Force Diagram	Aft BHD	Fore BHD
	SF target	SF Target
	$Q_{\text{targ-aft}}$ (-ve)	$Q_{\text{targ-fwd}}$ (+ve)
	$Q_{\text{targ-aft}}$ (+ve)	$Q_{\text{targ-fwd}}$ (-ve)
——— Vertical shear force after both adjustments - - - - - Vertical shear force after adjustment by use of $M_{Y_{aft}}$ and $M_{Y_{fore}}$ ..... Vertical shear force due to local loads		

**Table 3.8.3 (d): Distribution of adjusting vertical force at frames and resulting shear force distributions**

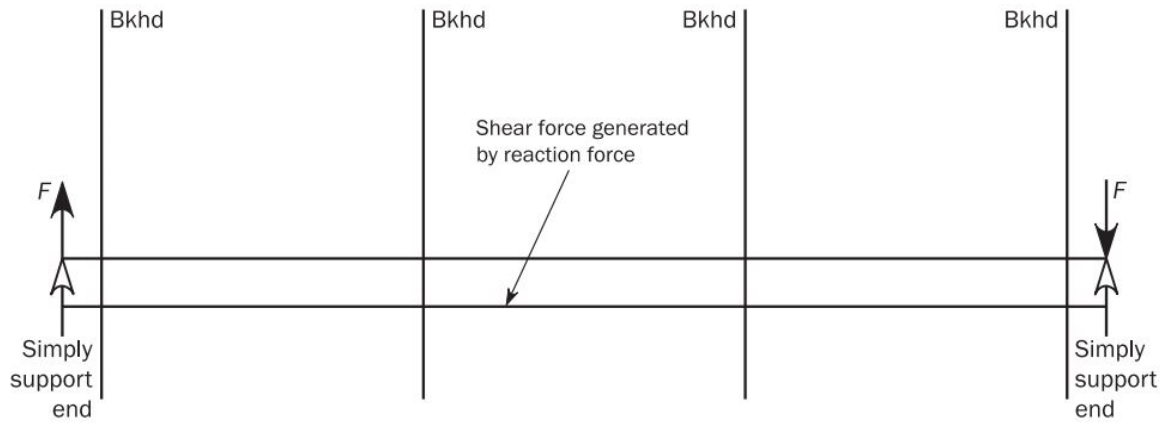


**Note:**

- Transverse bulkhead frames are not loaded
- Frames beyond aft transverse bulkhead of the aft most tank and forward bulkhead of the fore most tank are not loaded.
- F: Reaction Force generated by the supported ends



Shear Force distribution due to adjusting vertical force at frames



Note:  $F = 0$  if  $l_1 = l_3$  and  $\Delta l_{fore} = \Delta l_{end}$ , and loads are symmetrical about mid-length of model

**Note:** For the definition of relevant symbols refer *Table 3.8.3 (e)*

<b>Table 3.8.3 (e): Formulae for calculation of vertical loads for adjusting vertical shear forces</b>	
$\frac{\delta w_1 = \Delta Q_{aft}(2l - l_2 - l_3) + \Delta Q_{fwd}(l_2 + l_3)}{(n_1 - 1)(2l - l_1 - 2l_2 - l_3)}$	$F = 0.5 \left( \frac{W_1(l_2 + l_1) - W_3(l_2 + l_3)}{l} \right)$
$\delta w_2 = \frac{(W_1 + W_3)}{(n_2 - 1)} = \frac{(\Delta Q_{aft} - \Delta Q_{fwd})}{(n_2 - 1)}$	
$\frac{\delta w_3 = -\Delta Q_{fwd}(2l - l_1 - l_2) - \Delta Q_{aft}(l_1 + l_2)}{(n_3 - 1)(2l - l_1 - 2l_2 - l_3)}$	
<p><math>l_1</math> : Length of aft cargo hold of model, in m.  <math>l_2</math> : Length of mid-hold of model, in m.  <math>l_3</math> : Length of forward cargo hold of model, in m.  <math>\Delta Q_{aft}</math> : Required adjustment in shear force [kN] at aft bulkhead of middle hold, see [3.8.3.7],  <math>\Delta Q_{fwd}</math> : Required adjustment in shear force [kN] at fore bulkhead of middle hold, see [3.8.3.7]  <math>F</math> : End reactions [kN] due to application of vertical loads to frames.  <math>W_1</math> : Total evenly distributed vertical load [kNm] applied to aft hold of FE model, <math>(n_1 - 1)\delta w_1</math>.  <math>W_2</math> : Total evenly distributed vertical load [kN] applied to mid-hold of FE model, <math>(n_2 - 1)\delta w_2</math>.  <math>W_3</math> : Total evenly distributed vertical load [kN] applied to forward hold of FE model, <math>(n_3 - 1)\delta w_3</math>.  <math>n_1</math> : Number of frame spaces in aft cargo hold of FE model.</p>	

$n_2$	: Number of frame spaces in mid-hold of FE model.
$n_3$	: Number of frame spaces in forward cargo hold of FE model.
$\delta w_1$	: Distributed load [kN] at frame in aft cargo hold of FE model.
$\delta w_2$	: Distributed load [kN] at frame in mid-hold of FE model.
$\delta w_3$	: Distributed load [kN] at frame in forward cargo hold of FE model.
$\Delta l_{end}$	: Distance [m] between end bulkhead of aft cargo hold to aft end of FE model.
$\Delta l_{fore}$	: Distance [m] between fore bulkhead of forward cargo hold to forward end of FE model.
$l$	: Total length [m] of FE model including portions beyond end bulkheads: $= l_1 + l_2 + l_3 + \Delta l_{end} + \Delta l_{fore}$

**Note 1:** Positive direction of loads, shear forces and adjusting vertical forces in the formulae is in accordance with *Table 3.8.3 (c)* and *Table 3.8.3 (d)*.

**Note 2:**  $W_1 + W_3 = W_2$ .

**Note 3:** The above formulae are only applicable if uniform frame spacing is used within each hold. The length and frame spacing of individual cargo holds may be different.

- If non-uniform frame spacing is used within each cargo hold, the average frame spacing  $l_{av-i}$  is used to calculate the average distributed frame loads  $\delta w_{av-i}$ , according to *Table 3.8.3 (e)*, where  $i = 1, 2, 3$  for each hold. Then,  $\delta w_{av-i}$ , is redistributed to the non-uniform frame as follows:

$$\delta w_i^k = \delta w_{av-i} \cdot \frac{l_{av-i}^k}{l_{av-i}} \quad \{k = 1, 2, \dots, (n_i - 1), \text{ for each frame in cargo hold } i = 1, 2, 3\}$$

where,

$l_{av-i}$  : Average frame spacing [m] calculated as  $l_i/n_i$ , in hold  $i$  with  $i = 1, 2, 3$ .

$l_i$  : Length [m] of the cargo hold  $i$  with  $i = 1, 2, 3$  as defined in *Table 3.8.3 (e)*.

$n_i$  : Number of frames spacing in hold with  $i = 1, 2, 3$  according to *Table 3.8.3 (e)*.

$\delta w_{av-i}$  : Average uniform frame spacing [m] distributed force calculated according to *Table 3.8.3 (e)* with average frame spacing  $l_{av-i}$  in cargo hold with  $i = 1, 2, 3$ .

$\delta w_i^k$  : Distributed load [kN] for non-uniform frame  $k$  in cargo hold  $i$ .

$l_{av-i}^k$  : Equivalent frame spacing [m] for each frame  $k$  with  $k = 1, 2, \dots, n_i - 1$ , in cargo hold  $i$ , taken as:



$$l_{av-i}^k = l_i^1 - \frac{l_{av-i} \cdot l_i^1}{l_i^1 + l_i^{n_i}} + \frac{l_i^2}{2} \quad \text{[For } k = 1 \text{ (first frame), in cargo hold } i\text{]}$$

$$l_{av-i}^k = \frac{l_i^k}{2} + \frac{l_i^{k+1}}{2} \quad \text{[For } k = 2, 3 \dots (n_i - 2)\text{, in cargo hold } i\text{]}$$

$$l_{av-i}^k = l_i^{n_i} - \frac{l_{av-i} \cdot l_i^{n_i}}{l_i^1 + l_i^{n_i}} + \frac{l_i^{n_i-1}}{2} \quad \text{[For } k = n_i - 1 \text{ (last frame), in cargo hold } i\text{]}$$

$l_i^k$  : Frame spacing [m] between the frame  $k - 1$  and  $k$  in the cargo hold  $i$ .

- The required vertical load for a uniform frame spacing  $\delta w_i$  or  $\delta w_i^k$  for non-uniform frame spacing, are to be applied by following the shear flow distribution at the considered cross section as per section. For a frame section under vertical load  $\delta w_i$ , the shear flow,  $q_f$ , at the middle point of the element is calculated as:

$$q_{f-k} = \frac{\delta w_i}{I_{y-n50}} Q_{k-n50}$$

where,

$q_{f-k}$  : Shear flow calculated at the middle of the  $k$ -th element of the transverse frame [N/mm].

$\delta w_i$  : Distributed load at each transverse frame location for  $i$ -th cargo hold,  $i = 1, 2, 3$ , as defined in Table 3.8.3 (e) [N].

$I_{y-n50}$  : Moment of inertia of the hull girder cross section [mm<sup>4</sup>]

$Q_{k-n50}$  : First moment about neutral axis of the accumulative section area starting from the open end (shear stress free end) of the cross section to the point  $s_k$  for shear flow  $q_{f-k}$ , [mm<sup>3</sup>] taken as:

$$Q_{k-n50} = \int_0^{s_k} z_{neu} t_{n50} ds$$

$z_{neu}$  : Vertical distance from the integral point,  $s$ , to the vertical neutral axis.

$t_{n50}$  : Net thickness [mm], of the plate at the integral point of the cross section.

- The distributed shear force at  $j$ -th FE grid of the transverse frame  $F_{j-grid}$  is obtained from the shear flow of the connected elements as following:

$$F_{j-grid} = \sum_{k=1}^n q_{f-k} \frac{l_k}{2}$$

where,

$l_k$  : Length of the  $k$ -th element of the transverse frame connected to the grid  $j$  [mm].

$n$  : Total number of elements connected to the grid 'j'.

- The shear flow has direction along the cross section and therefore the distributed force,  $F_{j-grid}$  is a vector force. For vertical hull girder shear correction, the vertical and horizontal force components calculated with above mentioned shear flow method above need to be applied to the cross section.

### 3.8.3.8 Procedure to adjust vertical and horizontal bending moments for mid-ship cargo hold region

- In case the target vertical bending moment needs to be reached, an additional vertical bending moment is to be applied at both ends of the cargo hold FE model to generate this target value in the mid-hold of the model. This end vertical bending moment is given as follows:

$$M_{V-end} = M_{V-targ} - M_{V-peak}$$

where,

$M_{V-end}$  : Additional vertical bending moment [kN-m] to be applied to both ends of FE model in accordance with [3.8.3.10],

$M_{V-targ}$  : Hogging (positive) or sagging (negative) vertical bending moment [kN-m] as specified in [3.8.2 (a)].

$M_{V-peak}$  : Maximum or minimum bending moment [kN-m] within the length of the mid-hold due to the local loads described in [3.8.3.3] and due to the shear force adjustment as defined in [3.8.3.5].  $M_{V-peak}$  is to be taken as the maximum bending moment if  $M_{V-targ}$  is hogging (positive) and as the minimum bending moment if  $M_{V-targ}$  is sagging (negative).  $M_{V-peak}$  is to be calculated as based on the following formula:

$$M_{V-peak} = \text{Extremum} \left\{ M_{V-FEM}(x) + M_{LineLoad} + M_{Y-aft} \left( 2 \frac{x - x_{aft}}{x_{fore} - x_{aft}} - 1 \right) \right\}$$

$M_{V-FEM}(x)$  : Vertical bending moment [kN-m] at position x, due to the local loads as described in [3.8.3.3].

$M_{Y-aft}$  : End bending moment [kN-m] to be taken as:

- When Method 1 is applied: the value as defined in [3.8.3.6].
- When Method 2 is applied: the value as defined in [3.8.3.7].
- Otherwise:  $M_{Y-aft} = 0$

$M_{LineLoad}$  : Vertical bending moment [kN-m] at position x, due to application of vertical line loads at frames according to Method 2, to be taken as:

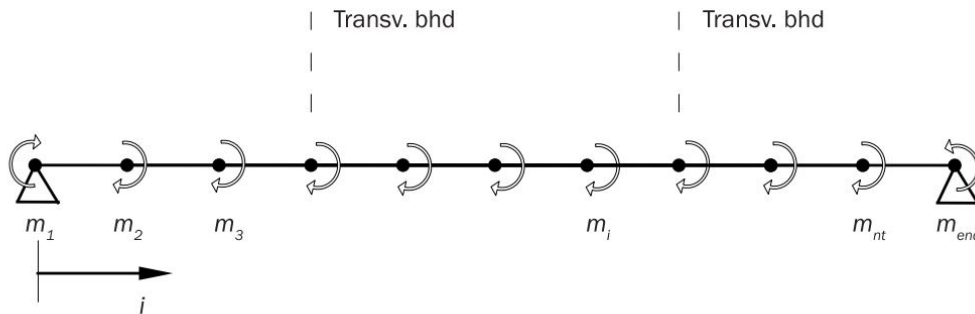
$$M_{LineLoad} = (x - x_{aft})F - \sum_i (x - x_i)\delta w_i$$

$F$  : Reaction force [kN] at model ends due to application of vertical loads to frames as defined in Table 3.8.3 (d).

$x$	: X-coordinate [m] of frame in way of the mid-hold.
$x_{aft}$	: X-coordinate at aft end support [mm]
$x_{fore}$	: X-coordinate at fore end support [mm]
$\delta w_i$	: Vertical load [kN] at web frame station $i$ applied to generate required shear force.

3.8.3.9 Procedure to adjust vertical bending moments outside mid-ship cargo hold region

- To reach the vertical hull girder target values at each frame and transverse bulkhead position, as defined in [3.8.2 (a)], the vertical bending moment adjustments,  $m_{vi}$ , are to be applied at web frames and transverse bulkhead positions of the finite element model, as shown below in *Figure 3.8.3 (a)*



$m_{hi}$  can be substituted to  $m_{vi}$  in this figure

**Figure 3.8.3 (a): Adjustments of bending moments outside mid-ship cargo hold region.**

- The vertical bending moment adjustment at each longitudinal location  $i$ , is to be calculated as follows:

$$f(i) = -M_{V-targ}(i) + M_{V-FEM}(i) + M_{lineload}(i) + M_{Y-aft}(i) \cdot \left( 2 \cdot \frac{x_i - x_{aft}}{x_{fore} - x_{aft}} - 1 \right)$$

$$m_{vi} = \frac{f(i) + f(i + 1)}{2} - \sum_{j=0}^{i-1} m_{vj}$$

$$m_{V-end} = - \sum_{j=0}^{n_t} m_{vj}$$

where,

$i$	: Index corresponding to the $i$ -th station, starting from $i = 1$ at the aft end section up to $n_t$ .
$n_t$	: Total number of longitudinal stations where the vertical bending moment adjustment, $m_{Vi}$ is applied.
$m_{Vi}$	: Vertical bending moment adjustment [kN-m] to be applied at transverse frame or bulkhead at station $i$ .
$m_{V-end}$	: Vertical bending moment adjustment [kN-m] to be applied, at the fore end section ( $n_{t+1}$ station).
$m_{Vj}$	: Argument of summation to be taken as:  $m_{Vj} = 0 \qquad \qquad \qquad \text{When } j = 0$ $m_{Vj} = m_{Vi} \qquad \qquad \qquad \text{When } j = i$
$M_{V-targ}(i)$	: Required target vertical bending moment [kN-m] at station $i$ , calculated in accordance with [3.8.2 (a)].
$M_{V-FEM}(i)$	: Vertical bending moment distribution [kN-m] at station $i$ due to local loads as given in [3.8.3.3].
$M_{lineload}(i)$	: Vertical bending moment [kN-m] at station $i$ , due to the line load for the vertical shear force correction as required in [3.8.3.8].

3.8.3.10 Application of bending moment adjustments on the FE model

— The required vertical and horizontal bending moment adjustments should be applied to the considered cross section of the cargo hold model. This process is carried out by distributing longitudinal axial nodal forces to all hull girder bending effective longitudinal elements of the considered cross section according to simple beam theory as explained below:

a) For vertical bending moment:

$$(F_x)_i = \frac{M_V}{I_{y-n50}} \cdot \frac{A_{i-n50}}{n_i} \cdot z_i$$

where,

$M_V$  : Vertical bending moment adjustment [kN-m] to be applied to the considered cross section of the model.

$(F_x)_i$  : Axial force [kN] applied to a node of the  $i$ -th element.

$I_{y-n50}$  : Hull girder vertical moment of inertia [m<sup>4</sup>] of the considered cross section about its horizontal neutral axis.

$z_i$  : Vertical distance [m] from the neutral axis to the centre of the cross-sectional area of the  $i$ -th element.

$A_{i-n50}$  : Cross sectional area [m<sup>2</sup>] of the  $i$ -th element.

$n_i$  : Number of nodal points of  $i$ -th element on the cross section,  $n_i = 1$  for beam element,  $n_i = 2$  for 4-node shell element.

- For cross sections other than at the ends of the model, the average area of the corresponding  $i$ -th elements forward and aft of the considered cross section is to be used.

### 3.8.4 Summary of hull girder load adjustments

The summary of the various sections to be referred for the adjustment procedures is tabulated in *Table 3.8.4*.

Table 3.8.4: Overview of hull girder adjustment procedures				
	Mid-ship cargo hold region	After and forward cargo hold region	Aft most cargo hold	Foremost cargo hold
Adjustment of Vertical Shear Forces	Refer [3.8.3.5]			
Adjustment of Bending Moments	Refer [3.8.3.8]	Refer [3.8.3.9]		

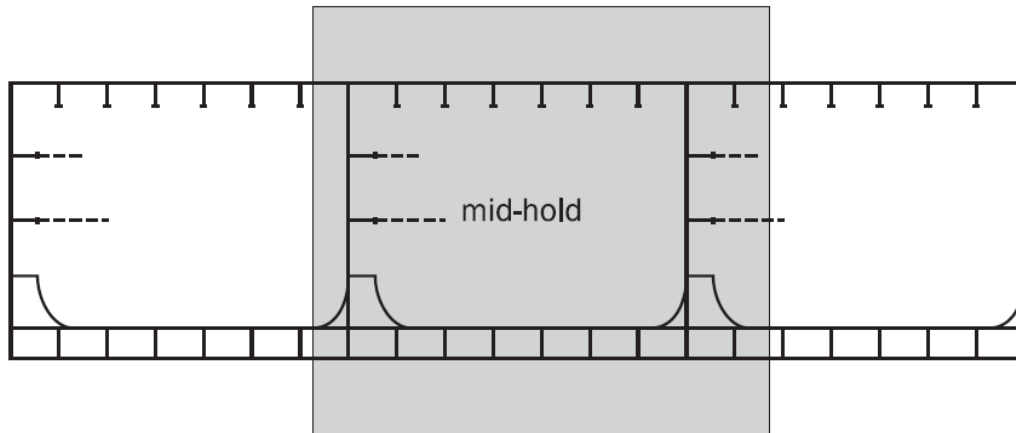
## 3.9 Analysis criteria

### 3.9.1 Evaluation area

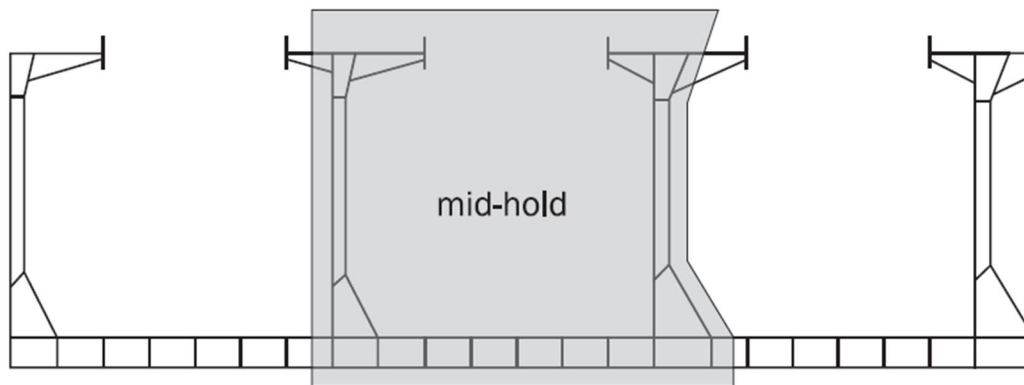
3.9.1.1 Mid-hold analysis: All the structural members within the evaluation area of the FE model needs to be evaluated for the yielding and the buckling strength assessment, specifically:

- All hull girder longitudinal members
- All primary supporting structural members such as web frames, cross ties etc.
- Transverse bulkheads, forward and aft of the mid hold.

Examples of the evaluation area selected for oil tankers and bulk carriers are illustrated in *Figures 3.9.1 (a)* and *3.9.1 (b)* respectively.



**Figure 3.9.1 (a): Longitudinal extent of evaluation area for oil tanker**



**Figure 3.9.1 (b): Longitudinal extent of evaluation area for bulk carrier**

### 3.9.2 Evaluation areas for cargo hold analysis pertaining to the foremost and aft most cargo holds

3.9.2.1 For the fore and aft most cargo hold regions the evaluation area is extended in order to include the following critical elements also, in the assessment process:

- i. Foremost cargo hold region

All the structural members which are a part of the collision bulkhead and extending to one web frame spacing forward of the collision bulkhead

- ii. Aft most cargo hold region

All structural members being part of the transverse bulkhead of the aft most cargo hold and all hull girder longitudinal structural members aft of this transverse bulkhead with the extent of 15% of the aft most cargo hold length.

### 3.9.3 Yield strength assessment

3.9.3.1 von Mises stress

For all plates of the structural members within the evaluation area, the von Mises stress,  $\sigma_{vm}$ , [N/mm<sup>2</sup>] is to be calculated based on the membrane normal and shear stresses of the shell element. The equivalent stresses are to be evaluated at the element centroid of the mid-plane (layer), as follows:

$$\sigma_{vm} = \sqrt{\sigma_x^2 - \sigma_x\sigma_y + \sigma_y^2 + 3\tau_{xy}^2}$$

where,

$\sigma_x, \sigma_y$  : Element normal membrane stresses [N/mm<sup>2</sup>]

$\tau_{xy}$  : Element shear stress [N/mm<sup>2</sup>]

3.9.3.2 Axial stress in beams

For beam and rod elements, the axial stress,  $\sigma_{axial}$ , [N/mm<sup>2</sup>] should be calculated based on axial stress alone. The axial stress needs to be evaluated at the middle of element length. The axial stress has to be calculated for the following members:

- Flange of primary supporting members,
- In dummy rod elements which are modelled with unit cross sectional properties, at the intersection between the flange and web of the corrugation.

3.9.3.3 Permissible stress

The coarse mesh permissible yield utilization factors,  $\lambda_{yperm}$ , given in *Table 3.9.3 (a)*, are based on the element types and the mesh size described in this section. Whenever, the geometry is incapable of being represented in the cargo hold model and the stress exceeds the allowable criteria, then a finer mesh needs to be used to adequately demonstrate satisfactory scantling. Where a smaller mesh size is used, an average weighted von Mises stress calculated over an area equivalent to the specified mesh size required for the partial ship model needs to be used to comply with the coarse mesh permissible yield utilization factors. Stress averaging is not to be carried across structural discontinuities and abutting structure

3.9.3.4 Coarse mesh permissible yield utilization factors

The permissible coarse mesh yield utilization factors,  $\lambda_{yperm}$ , given in *Table 3.9.3 (a)*, are based on the element types and the mesh size described in *Section 4*, [4.5]. The yield utilization factor resulting from element stresses of each structural component is not to exceed the permissible values as given in *Table 3.9.3 (a)*.

Table 3.9.3 (a): Permissible coarse mesh yield utilization factor, $\lambda_{yperm}$		
Structural Member	Load components	$\lambda_{yperm}$
Plating of all longitudinal hull girder structural members, primary supporting structural members and bulkheads.	S	0.80

Dummy rod of corrugated bulkhead. Face plate of primary supporting members modelled using shell or rod elements.	S+D	1.0
Corrugation of corrugated bulkheads under lateral pressure from liquid loads, for shell elements only.	S	0.72
	S+D	0.90

3.9.3.5 Allowable criteria and coarse mesh permissible yield utilization factors

The results from cargo hold analysis should illustrate that the stresses obtained from the FE analysis do not exceed the coarse mesh permissible yield utilization factors, as follows:

$$\lambda_y \leq \lambda_{yperm}$$

where,

$\lambda_y$  : Yield utilization factor

$$\lambda_y = \frac{\sigma_{vm}}{\sigma_y} ; \quad \text{For plate elements in general}$$

$$\lambda_y = \frac{\sigma_{axial}}{\sigma_y} ; \quad \text{For rod or beam elements in general}$$

$\sigma_{vm}$  : von Mises Stress [N/mm<sup>2</sup>]

$\sigma_{axial}$  : Axial stress in rod element [N/mm<sup>2</sup>]

$\lambda_{yperm}$  : Coarse mesh permissible yield utilization factor, as given in the *Table 3.9.3 (a)*

$\sigma_y$  : Nominal yield stress, taken equal to 235/k

3.9.3.6 Corrugation of corrugated bulkheads

The stress in corrugation of corrugated bulkheads is to be evaluated based on:

- i. The von Mises stress,  $\sigma_{vm}$ , in the shell elements on the flange and web of the corrugation.
- ii. The axial stress,  $\sigma_{axial}$ , in dummy rod elements, modeled with unit cross-sectional properties at the intersection between the flange and web of the corrugation.

3.9.3.7 Simplified shear stress correction for openings

In the presence of cut-outs, the yield utilization factor needs to be corrected using the simplified shear stress correction factor. Correspondingly, the yield criteria should be satisfied utilizing this corrected yield utilization factors as:

$$\lambda_y = \frac{\lambda_{y,FE}}{C_r}$$

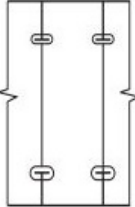
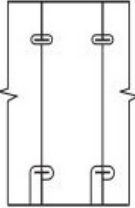
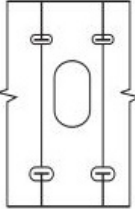
where,



---

$\lambda_{y,FE}$	: Yield utilization factor from FE assessment with openings not reflected in the model
$C_r$	: Reduction factor for yield criteria as given in <i>Table 3.9.3 (b)</i> .

Table 3.9.3 (b): Simplified shear stress correction

Identification	Figure	Difference between modelled shear area and the net effective shear area in % of the modelled shear area $\frac{A_{FEM-n50} - A_{shr-n50}}{A_{FEM-n50}} \cdot 100\%$	Reduction factor for yield criteria, $C_r$
Upper and lower slots for local support stiffeners fitted with lugs or collar plates		< 15%	0.85
Upper or lower slots for local support stiffeners fitted with lugs or collar plates		< 20%	0.80
In way of opening; upper and lower slots for local support stiffeners fitted with collar plates		< 40%	0.60

$A_{shr-n50}$ : Effective net shear area of the web [mm<sup>2</sup>] taken as the web area without the all opening areas and without the slots for stiffeners.

3.9.3.8 Shear stress correction for cut-outs

Except as indicated in [3.9.3.5], the element shear stress in way of cut-outs in webs should be corrected for loss in shear area in accordance with the following formula. The corrected element shear stress needs to be used to calculate the von Mises stress of the element for verification against the yield criteria.

$$\tau_{corr} = \frac{h \cdot \tau_{mod-n50}}{A_{shr-n50}} \tau_{elem}$$

where,

$\tau_{corr}$  : Corrected element shear stress [N/mm<sup>2</sup>]

h : Height of web of girder [mm], in way of opening, refer Table 3.4.4. Where the geometry of the opening is modelled, h is to be taken as

the height of web of the girder deducting the height of the modelled opening.

$t_{mod-n50}$  : Modelled web thickness [mm], in way of opening.

$A_{shr-n50}$  : Effective net shear area of web [mm<sup>2</sup>], taken as the web area deducting the area loss of all openings, including slots for stiffeners, calculated as given in [3.9.3.9].

$\tau_{elem}$  : Element shear stress [N/mm<sup>2</sup>] before correction.

3.9.3.9 Shear area of primary supporting members with web openings

The effective web height,  $h_{eff}$ , in mm, to be considered for calculating the effective net shear area,  $A_{shr-n50}$  is to be taken as the lesser of:

$$h_{eff} = h_w$$

$$h_{eff} = h_{w3} + h_{w4}$$

$$h_{eff} = h_{w1} + h_{w2} + h_{w4}$$

where:

$h_w$  : Web height of primary supporting member, in mm.

$h_{w1}, h_{w2}, h_{w3}, h_{w4}$  : Dimensions as shown in *Figure 3.9.3*.

Where an opening is located at a distance less than  $h_w/3$  from the cross-section considered,  $h_{eff}$  is to be taken as the smaller of the net height and the net distance through the opening. Refer *Figure 3.9.3*.

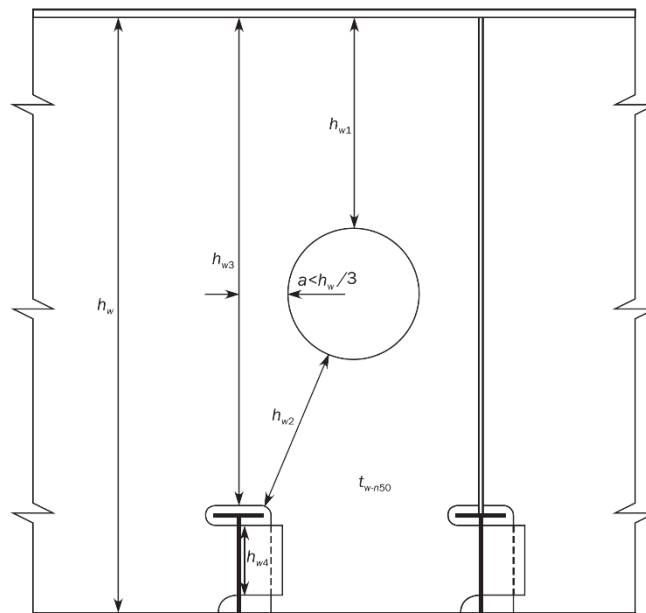


Figure 3.9.3: Effective shear area in way of opening

3.9.4 Buckling strength assessment

- 3.9.4.1 Applicable structural locations/details/members are to be selected and evaluated as provided in the IRS Rules for Bulk Carriers and Oil Tankers, Vol.2, Chapter 8 for buckling strength assessment.
- 3.9.4.2 IRS will specially consider buckling strength evaluation using non-linear finite element techniques in lieu of the provisions on 2.5.3.1. For this purpose, it has to be demonstrated to the satisfaction of the IRS that the program using non-linear finite element techniques gives satisfactory results. The program is to be able to consider the effects of initial imperfections in the plating according to IACS Recommendation. 47 and residual stresses.
- 3.9.5 Fatigue strength assessment
  - 3.9.5.1 Applicable structural locations/details/members are to be selected as described in IRS Rules Part 3 and Part 5 and IRS Guideline IRS-G-DES-07.

---

## Section 4

### Local Structural Strength Analysis

#### 4.1 Scope and application

- 4.1.1 Local analysis is the subsequent assessment after performing either the full ship analysis or the three cargo hold analysis. The local strength analysis of structural details is to be performed if deemed critical by IRS. Present section details the procedure of local strength analysis.
- 4.1.2 Fine mesh FE analysis is to be carried out for structural details for specific ships as given in *Part 5*, as applicable. Such analysis may also be carried out for any details that are deemed critical by IRS.
- 4.1.3 The local analysis is performed to verify the adequacy of local structural details for yielding in accordance with [4.6].

#### 4.2 Local areas to be assessed by fine mesh

##### 4.2.1 General

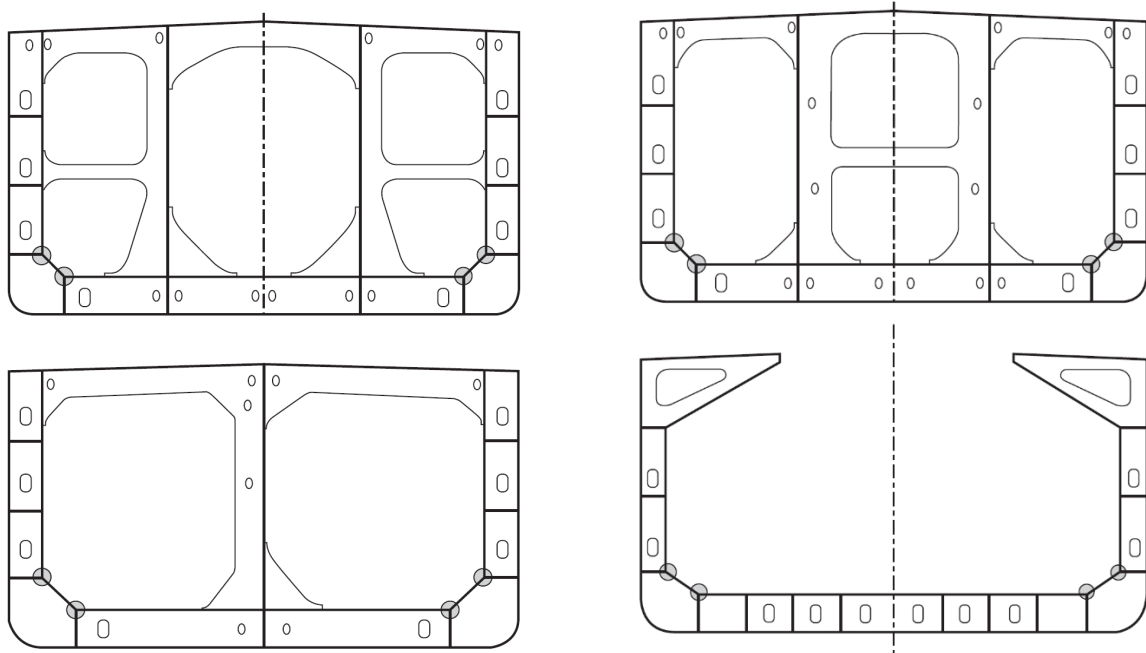
- 4.2.1.1 Structural details in the mid-ship cargo hold region to be assessed by fine mesh analysis are modelled as detailed such as:

- Hopper knuckle
- Frames end bracket
- Large openings
- Connections of deck and double bottom longitudinal stiffener to transverse bulkhead
- Connections of corrugation to adjoining structure
- Bracket at the heel of horizontal stringer
- Hatch corner area
- Scarfing and termination of primary structural members
- Crane & Other Heavy Equipment Foundations

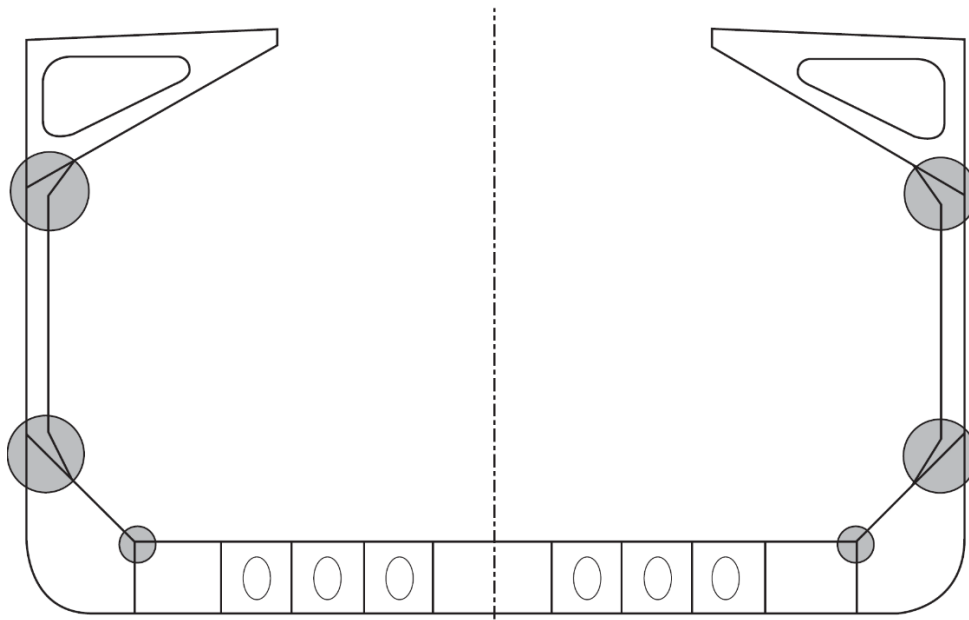
- 4.2.1.2 For each of the above-mentioned structural details, one fine mesh model is required within all the cargo hold models covering the mid-ship cargo hold region. The selection of the location of fine mesh model is to be based on requirements given in [4.2.2] to [4.2.7] for all cargo hold analyses in the mid-ship cargo hold region.

- 4.2.2 Hopper knuckles for ship with double side

- 4.2.2.1 Fine mesh analysis is to be carried out for the lower and upper hopper knuckles of either welded or bent type, in way of a typical transverse web frame, as indicated in *Figure 4.2.2*.
- 4.2.2.2 For double side arrangements without the hopper plating, i.e. where the inner hull longitudinal bulkhead is fitted directly to the inner bottom, fine mesh analysis is to be carried out for the heel of the transverse web frame.
- 4.2.2.3 The transverse web frame which, in the cargo hold analysis, has the maximum yield utilisation factor,  $\lambda_y$  in knuckle is to be selected for the fine mesh analysis.



**Figure 4.2.2: Mandatory areas at hopper knuckles for ships with double side**



**Figure 4.2.3: Mandatory areas at lower upper knuckle and side frame end brackets for single side bulk carrier**

#### 4.2.3 Side frame end brackets and lower hopper knuckle

4.2.3.1 Fine mesh analysis is to be carried out for the lower hopper knuckle of either welded or bent type, lower and upper end bracket of side frame, as indicated in *Figure 4.2.3*.

4.2.3.2. The side frame which in the cargo hold analysis has the maximum yield utilisation factor,  $\lambda_y$ , in end bracket joints is to be selected for the fine mesh analysis.

#### 4.2.4 Large openings

4.2.4.1 Large openings in way of primary supporting members, for which their geometry is required to be represented in the cargo hold model in accordance with *Section 3, [3.4.4.5]* are to be assessed by fine mesh analysis.

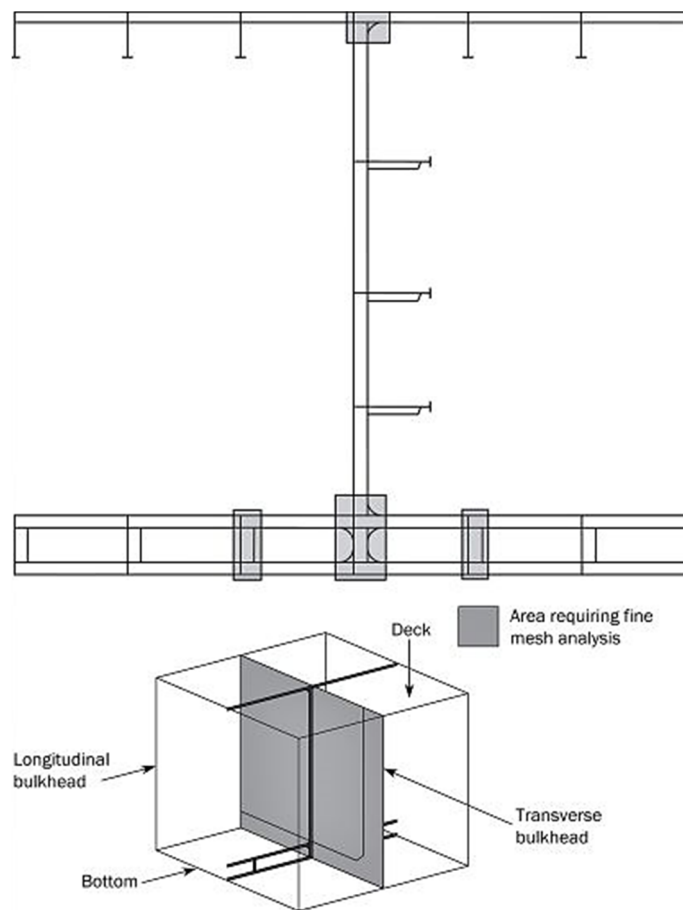
4.2.4.2 The structural member in way of the large openings having the maximum yield utilisation factor,  $\lambda_y$ , in the cargo hold analysis is to be selected for the fine mesh analysis.

#### 4.2.5 Connections between deck and double bottom longitudinal stiffeners and adjoining structures of transverse bulkhead

4.2.5.1 Fine mesh analysis is to be carried out for the connections of deck and double bottom longitudinal stiffeners and adjoining structures of transverse bulkhead, either plane or corrugated bulkhead. The adjoining structures of transverse bulkhead include the structural members in way of the bulkhead, the partial deck girders and partial double bottom girders, if any. For example, the following structural members are to be assessed, some of them being shown in *Figure 4.2.5*.

- At least one pair of connections between inner and outer bottom longitudinal stiffeners and adjoining structures of transverse bulkhead.
- At least one pair of connections between inner and outer bottom longitudinal stiffeners and adjoining structures of adjacent floor to the transverse bulkhead.
- At least one connection between deck longitudinal stiffener (fitted above or below deck) and adjoining vertical structure of transverse oil tight bulkhead.
- Connection between deck longitudinal partial girder on top of transverse oil tight bulkheads when fitted and adjoining vertical structure of transverse oil tight bulkhead.
- Connection between bottom longitudinal partial girder in way of transverse oil tight bulkheads when fitted and adjoining vertical structure of transverse oil tight bulkhead.

4.2.5.2 The selection of the connections between longitudinal and vertical stiffeners to be analysed is to be based on the maximum relative deflection between supports, i.e. between floor and transverse bulkhead or between deck transverse and transverse bulkhead. Where there is a significant variation in end connection arrangement between stiffeners or scantlings, analyses of additional connections may be required by IRS.



**Figure 4.2.5: Mandatory area connection between double bottom and deck longitudinals and adjoining structure of transverse bulkhead**



4.2.5.3 Outside the mid-ship cargo hold region, the scantlings of the connections as given above are not to be less than the required scantlings obtained for the mid-ship cargo hold region unless an equivalent strength is demonstrated by fine mesh analysis.

#### 4.2.6 Connection between corrugation and adjoining structure

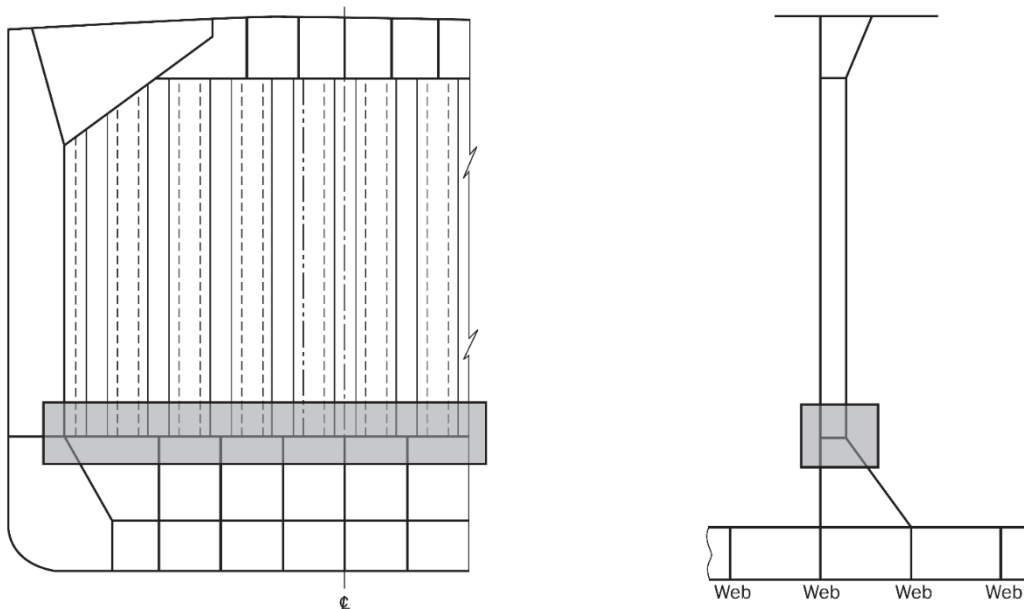
4.2.6.1 Fine mesh analysis is to be carried out for connections between corrugation and adjoining lower supporting structures. For example, the following structure members, as shown in *Figure 4.2.6*, are to be assessed.

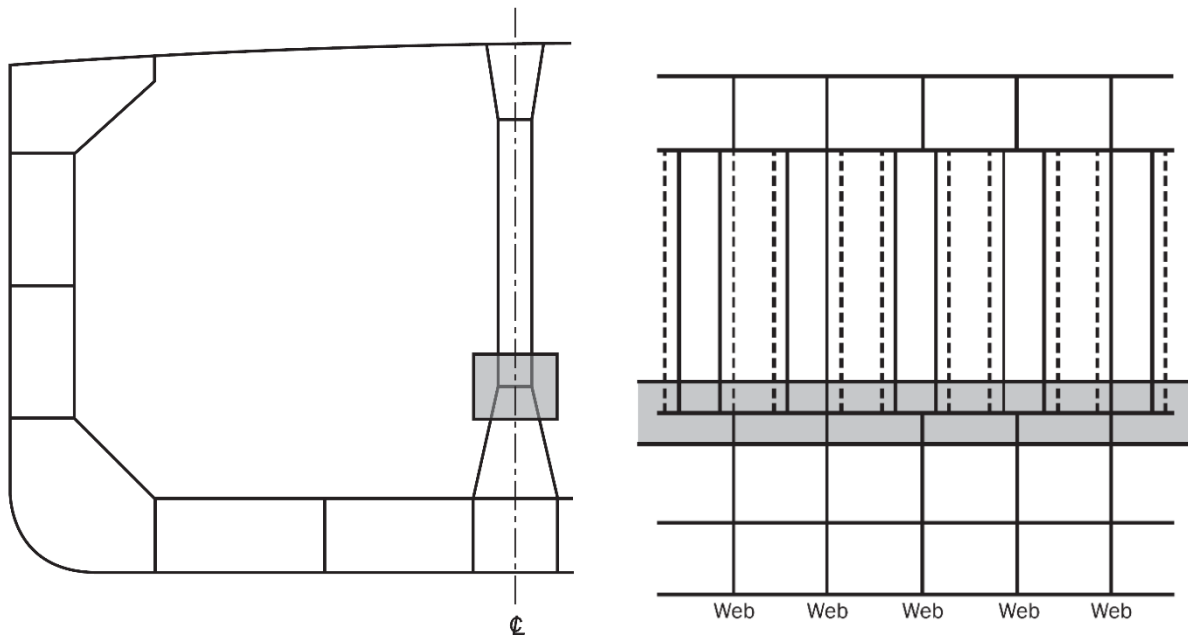
- Connection of the corrugation and supporting structure in way of lower stool shelf plate
- Connection of the corrugation and lower supporting structure to inner bottom if no stool is fitted.
- Connection of the corrugation and upper corner of the gusset plate if shedder plate with a gusset plate is fitted at top of the lower stool.

4.2.6.2 The corrugation unit which, in the cargo hold analysis, has the maximum yield utilisation factor,  $\lambda_y$ , in way of the corrugation connection, is to be selected for the fine mesh analysis.

4.2.6.3 Where there is a significant variation in arrangement of supporting structures of the corrugation, analysis of additional location may be required by IRS.

4.2.6.4 For ships with both longitudinal and transverse corrugated bulkheads, fine mesh analysis is required for the connection between corrugation and supporting structure in way of the lower stool shelf plate or inner bottom, if no stool is fitted, at the intersection between longitudinal and transverse bulkheads.





**Figure 4.2.6: Mandatory area connection between corrugation and adjoining stool**

#### 4.2.7 Bracket at the heel of horizontal stringer

4.2.7.1 Fine mesh analysis is to be carried out for the bracket at the heel of horizontal stringers. All structural elements adjacent to the heel including the inner hull, longitudinal and transverse bulkhead are to satisfy the allowable stress criteria. The heel of horizontal stringer which, in the cargo hold analysis, has the maximum yield utilization factor,  $\lambda_y$ , is to be selected for the fine mesh analysis. Where there is a significant variation in the arrangement of the bracket at the heel and the horizontal stringer, analysis of additional locations may be required by IRS.

### 4.3 Structural model

#### 4.3.1 General

4.3.1.1 Evaluation of detailed stresses requires the use of refined finite element mesh in way of areas of high stress. The fine mesh analysis can be carried out by fine mesh zones incorporated into the cargo hold model. Alternatively, equivalent local FE model with fine mesh zones in conjunction with the boundary conditions obtained from the cargo hold model may be used.

4.3.1.2 Local fine mesh zone is to be made of shell elements considering the bending and membrane properties.

#### 4.3.2 Extent of model

4.3.2.1 If a separate local fine mesh model is used, its extent is to be such that the calculated stresses at the areas of interest are not significantly affected by the imposed boundary conditions. The boundary of the fine mesh model is to coincide with primary supporting members in the cargo hold model, such as web frame, girders, stringers and floors.

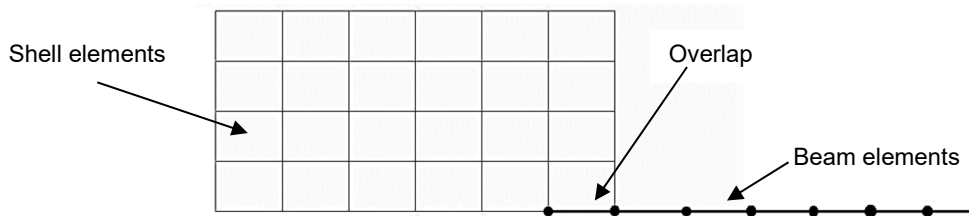
### 4.3.3. Mesh size

4.3.3.1 The mesh size in the fine mesh zone is not to be greater than 50×50 mm.

4.3.3.2 The extent of the fine mesh zone is not to be less than 10 elements in all directions from area under evaluation. A smooth transition of mesh density from coarser mesh to fine mesh zone is to be maintained

### 4.3.4. Elements

4.3.4.1 All plating within the fine mesh zone is to be represented by shell elements. The aspect ratio of elements within the fine mesh zone is to be kept as close to 1 as possible. Variation of mesh density within the fine mesh zone and the use of triangular elements are to be avoided. In all cases, the elements within the fine mesh model are to have an aspect ratio not exceeding 3. Distorted elements, with element corner angles of less than 45° or greater than 135°, are to be avoided. Stiffeners inside the fine mesh zone are to be modelled using shell elements. Stiffeners outside the fine mesh zones may be modelled using beam elements. The overlap beam element can be applied as shown in *Figure 4.3.4 (a)*.



**Figure 4.3.4 (a): Overlap element in transition from shell to beam elements**

4.3.4.2 Where fine mesh analysis is required for main bracket end connections, including the end connection of hold frames, the fine mesh zone is to be extended at least 10 elements in all directions from the area subject to assessment, see *Figure 4.3.4 (b)*.

4.3.4.3 Where fine mesh analysis is required for an opening, the first two layers of elements around the opening are to be modelled with mesh size not greater than 50 x 50 mm. A smooth transition from the fine mesh to the coarser mesh is to be maintained. Edge stiffeners which are welded directly to the edge of an opening are to be modelled with shell elements. Web stiffeners close to an opening may be modelled using rod or beam elements located at a distance of at least 50 mm from the edge of the opening. Example of fine mesh zone around an opening is shown in *Figure 4.3.4 (c)*.

4.3.4.4 Face plates of openings, primary supporting members and associated brackets are to be modelled with at least two elements across their width on either side.

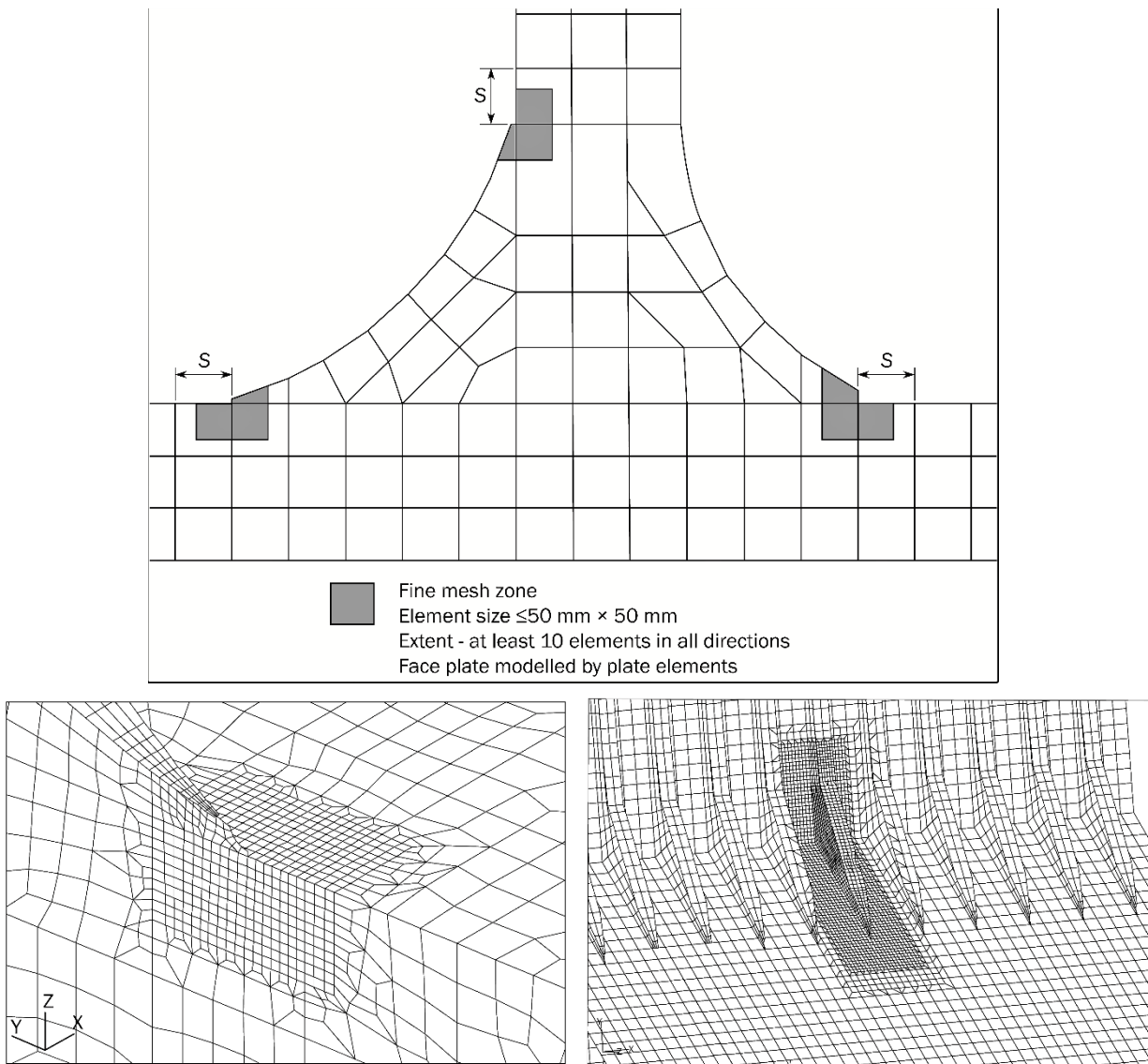
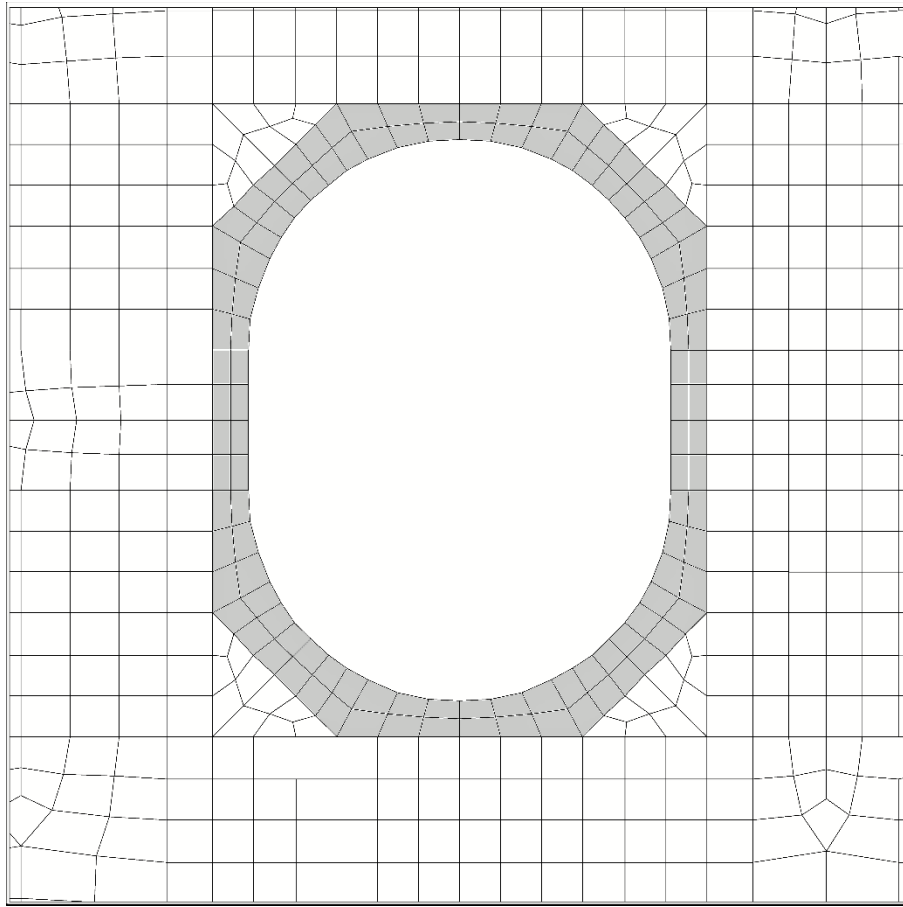


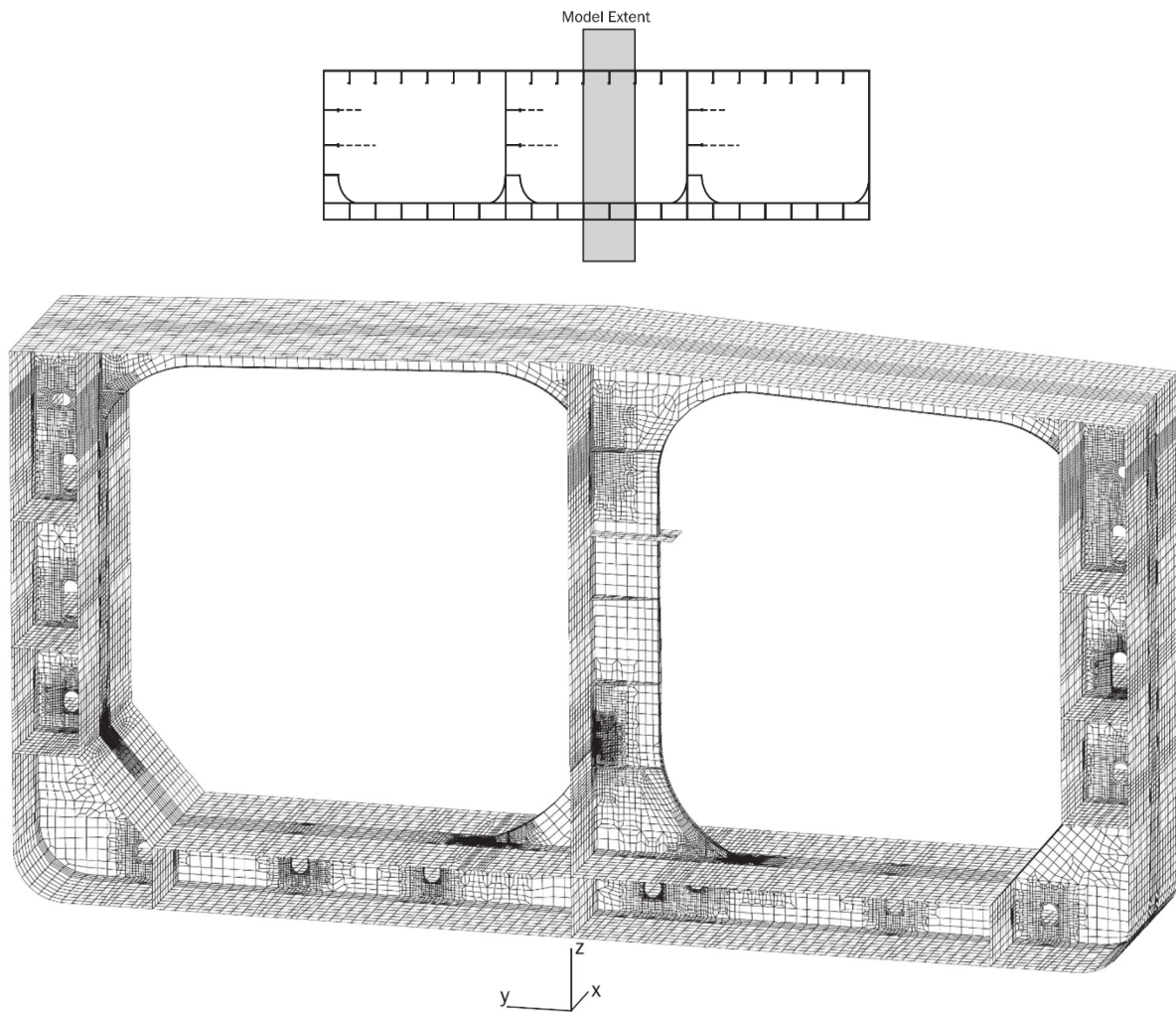
Figure 4.3.4 (b): Fine mesh zone around bracket toe



**Figure 4.3.4 (c): Fine mesh zone around an opening**

#### 4.3.5 Transverse Web Frames

- 4.3.5.1 In addition to the requirements of [4.3.2] to [4.3.4], the modelling requirements in this sub-section are applicable to the analysis of a typical transverse web frame.
- 4.3.5.2 Where a FE sub model is used, the model is to have an extent of at least 1+1 web frame spaces, i.e. one web frame space extending either side of the transverse web frame under investigation.
- 4.3.5.3 The full depth and full breadth of the ship are to be modelled, see *Figure 4.3.5 (a)*. *Figure 4.3.5 (b)* shows a close-up view of the finite element mesh at the lower part of the vertical web and backing brackets.



**Figure 4.3.5 (a): Example of extent of local model for fine mesh analysis of web frame bracket connections and openings**

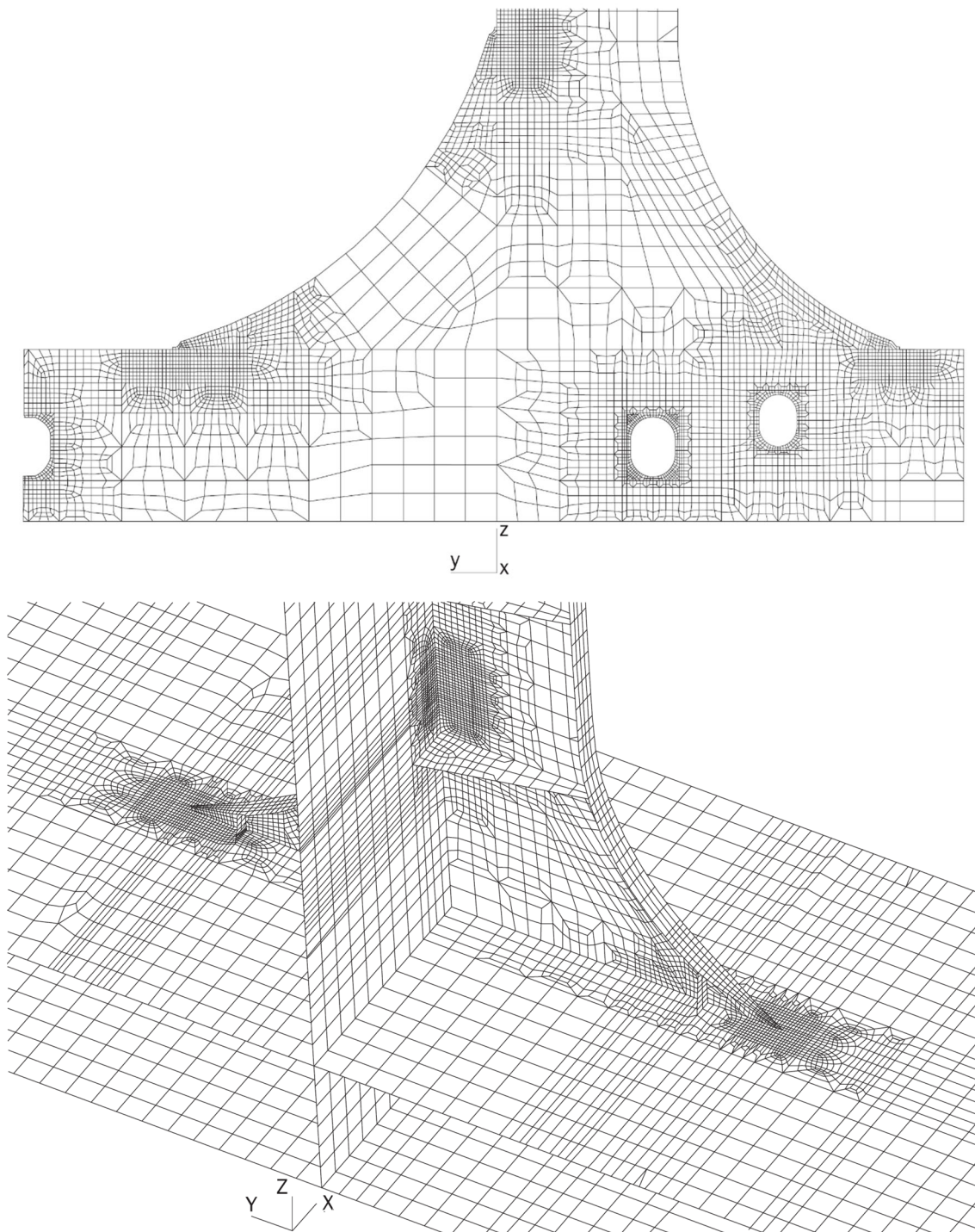
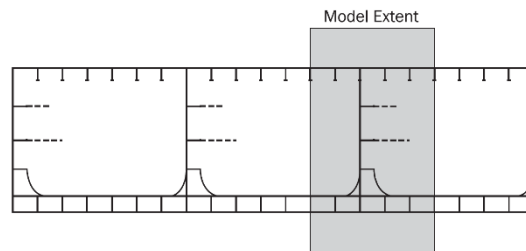


Figure 4.3.5 (b): Close-up view of FE mesh at lower part of a transverse web frame

#### 4.3.6 Transverse bulkhead stringers, buttress and adjacent web frames

- 4.3.6.1 In addition to the requirements of *Section 4*, [4.3.2] to [4.3.4], the modelling requirements in this sub-section are applicable to the analysis of a typical transverse bulkhead structures and adjacent web frame.
- 4.3.6.2 Due to the structural interaction among the transverse bulkhead, horizontal stringers, web frames, deck and double bottom, it is recommended that the FE local model represents a full section of the hull. Longitudinally, the ends of the model should be extended at least one web frame space beyond the areas that require investigation, see *Figure 4.3.6 (a)*.
- 4.3.6.3 Alternatively, it is acceptable to use a number of local models, as shown in *Figure 4.3.6 (b)*, to analyse different parts of the structure. For the analysis of the transverse bulkhead horizontal stringers the full breadth of the ship is to be modelled. For the analysis of buttress structure, the local model width should be at least 4+4 longitudinal spaces, i.e. four longitudinal spaces at each side of the buttress.
- 4.3.6.4 *Figure 4.3.6 (c)* shows the finite element mesh on a transverse bulkhead horizontal stringer. *Figure 4.3.6 (d)* shows the local model for the analysis of buttress connections to transverse bulkhead and double bottom structure, and openings.





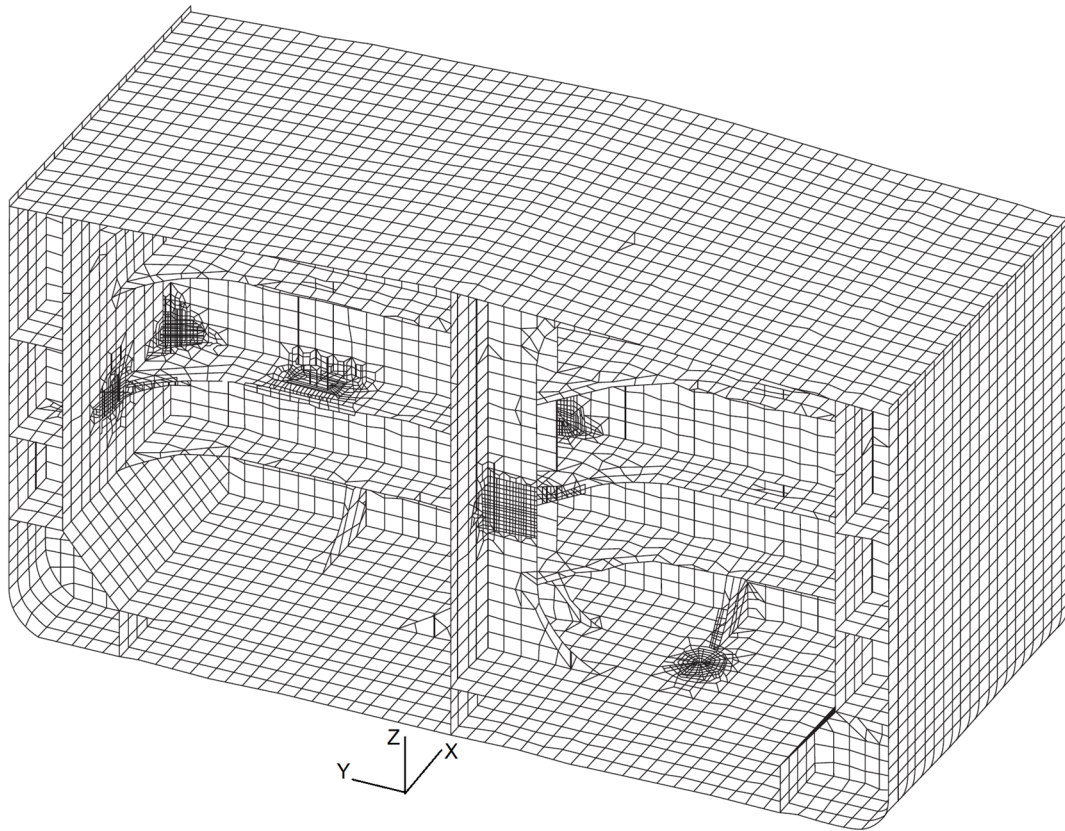


Figure 4.3.6 (a): Extent of local model for fine mesh analysis of transverse bulkhead and adjoining structure

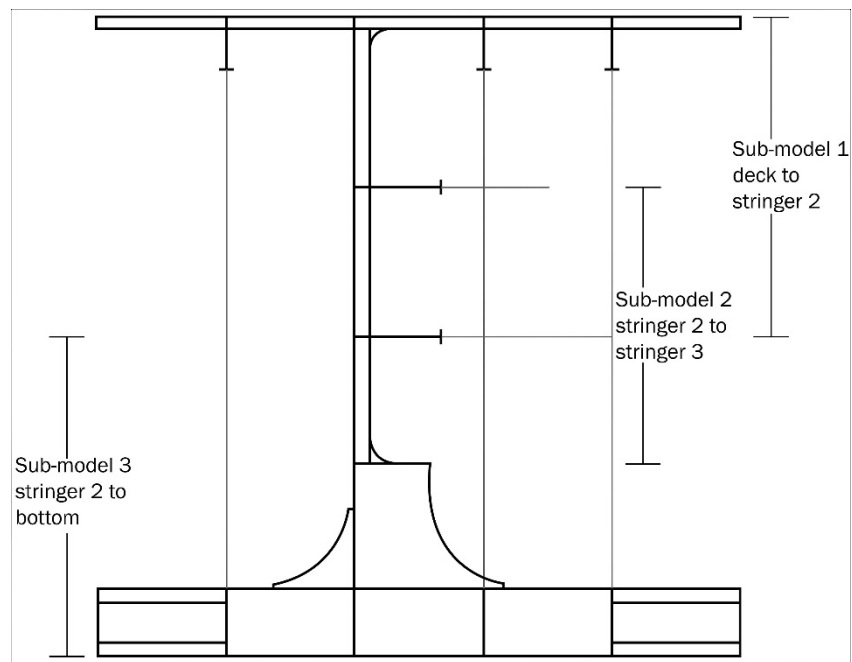


Figure 4.3.6 (b): Example of local analysis of transverse bulkhead structure using local models

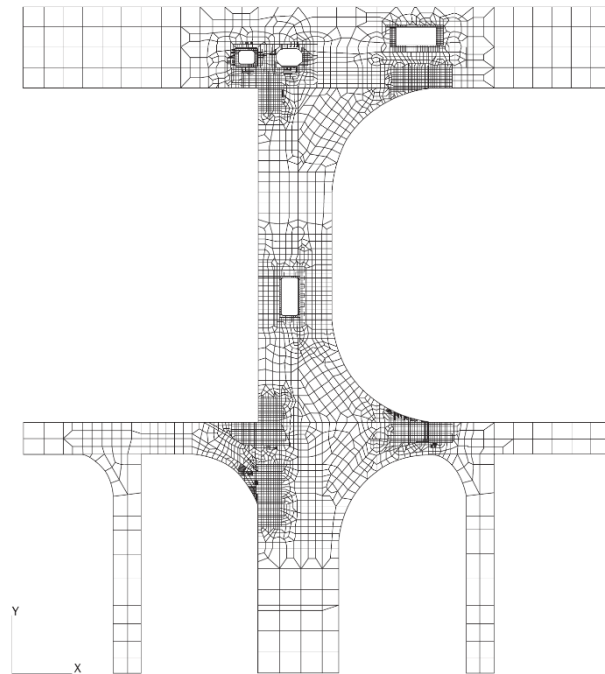
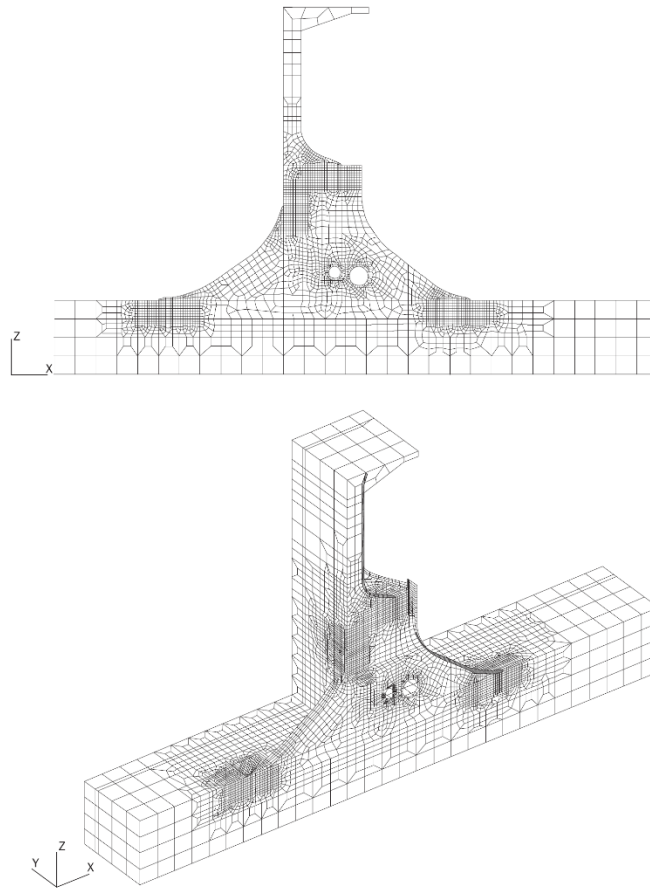


Figure 4.3.6 (c): Example of finite element mesh on transverse bulkhead horizontal stringer



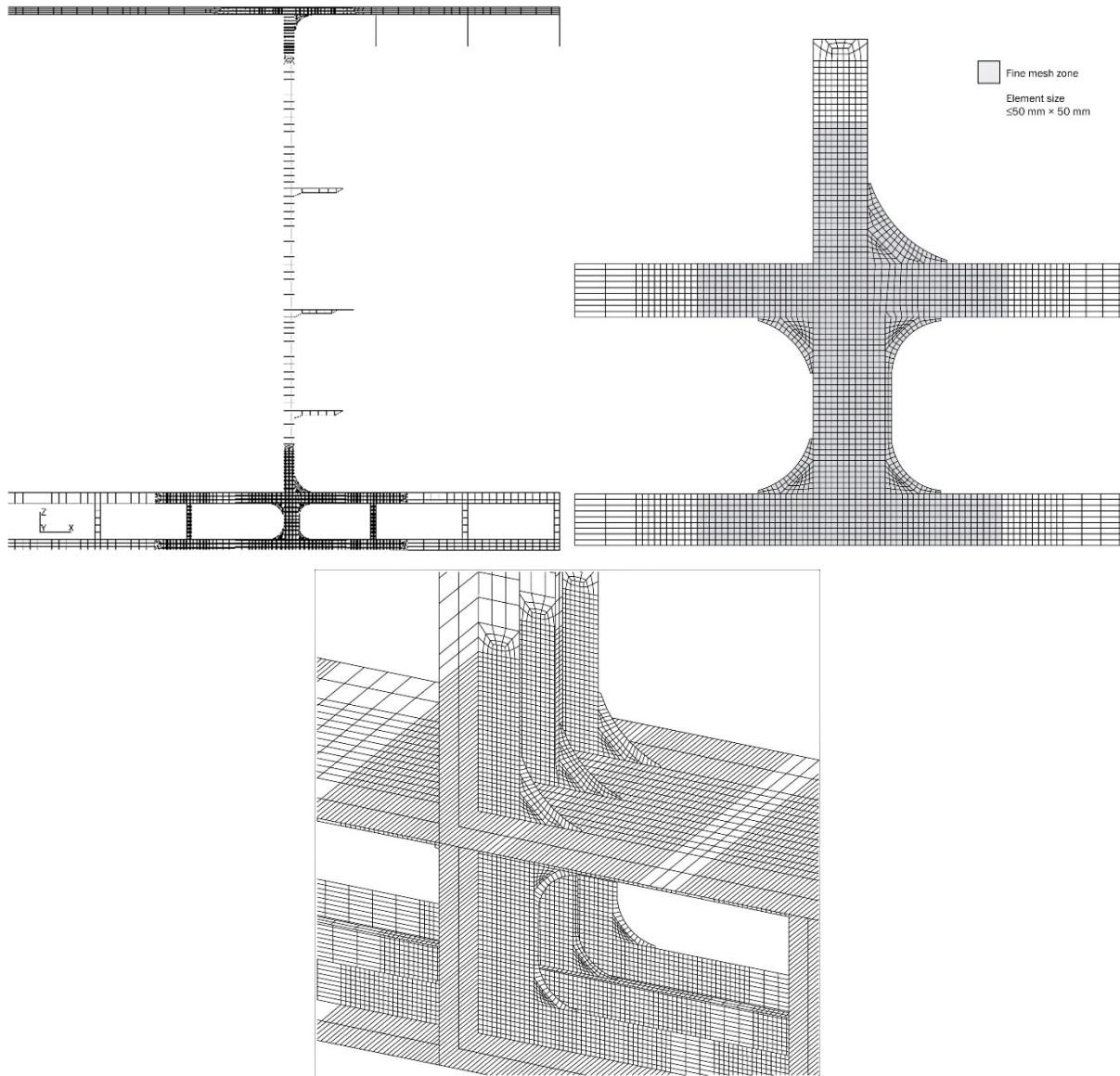
**Figure 4.3.6 (d): Example of local model for the analysis of buttress connections to bulkhead and double bottom structure, showing port half of model**

4.3.7 Deck, double bottom longitudinal and adjoining transverse bulkhead vertical stiffeners

4.3.7.1 In addition to the requirements of [4.3.2] to [4.3.4], the modelling requirements in this sub-section are applicable to the analysis of longitudinal and vertical stiffener end connection and attached web stiffeners.

4.3.7.2 Where a local FE model is used, each end of the model is to be extended longitudinally at least two web frame spaces from the areas under investigation. The model width is to be at least 2+2 longitudinal spaces. *Figure 4.3.7* shows the longitudinal extent of the local model for the analysis of deck and double bottom longitudinal stiffeners and adjoining transverse bulkhead vertical stiffener.

4.3.7.3 The web of the longitudinal stiffeners outside of the fine mesh zone should be represented by at least 3 shell elements across its depth. Similar size elements should be used to represent the plating of the bottom shell and inner bottom. The flange of the longitudinal stiffeners and face plate of brackets should be modelled with at least two shell elements across its width at one side.



**Figure 4.3.7: Example of local analysis of deck, double bottom longitudinal and adjoining transverse bulkhead vertical stiffeners**

#### 4.3.8 Corrugated bulkheads

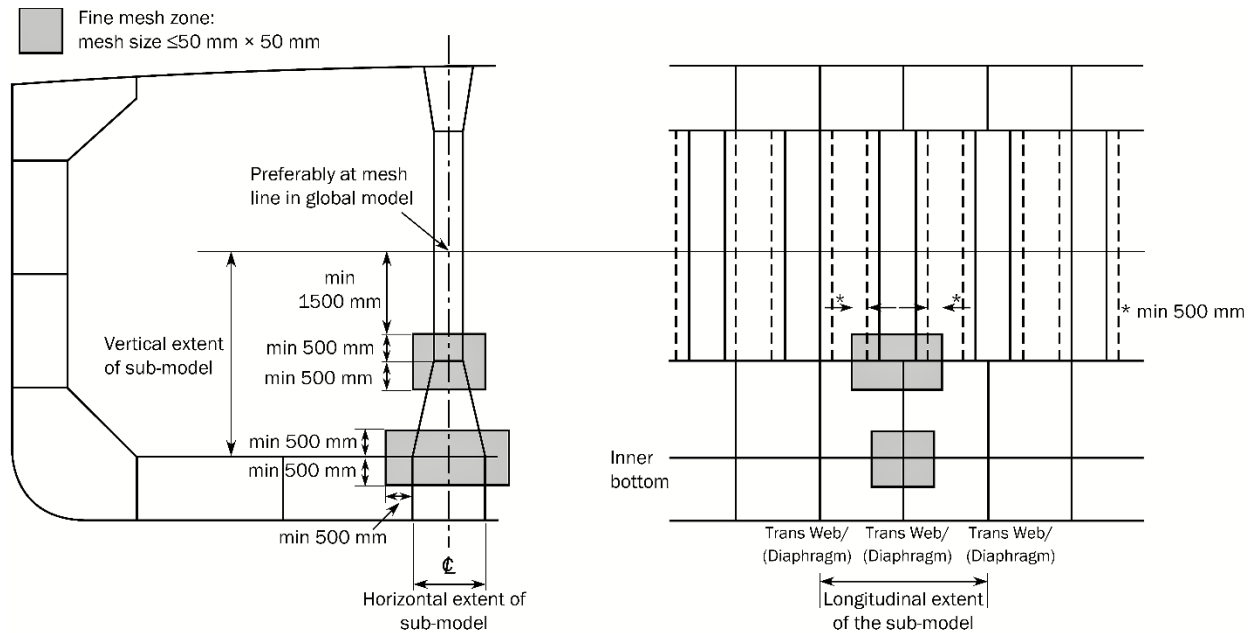
4.3.8.1 In addition to the requirements of [4.3.2] to [4.3.4], the modelling requirements in this sub-section are applicable to the analysis of connection of corrugated bulkheads to lower stool and the connection between lower stool and inner bottom.

4.3.8.2 The minimum extents of the local model are as follows, see also *Figure 4.3.8 (a)*.

- Vertically, the model is to be extended from the bottom of the ship to a level at least 2 m above the corrugation and lower stool connection. The upper boundary of the local model is to coincide with the horizontal mesh line of the cargo hold FE model for the purpose of applying boundary displacements, see [4.3.2].

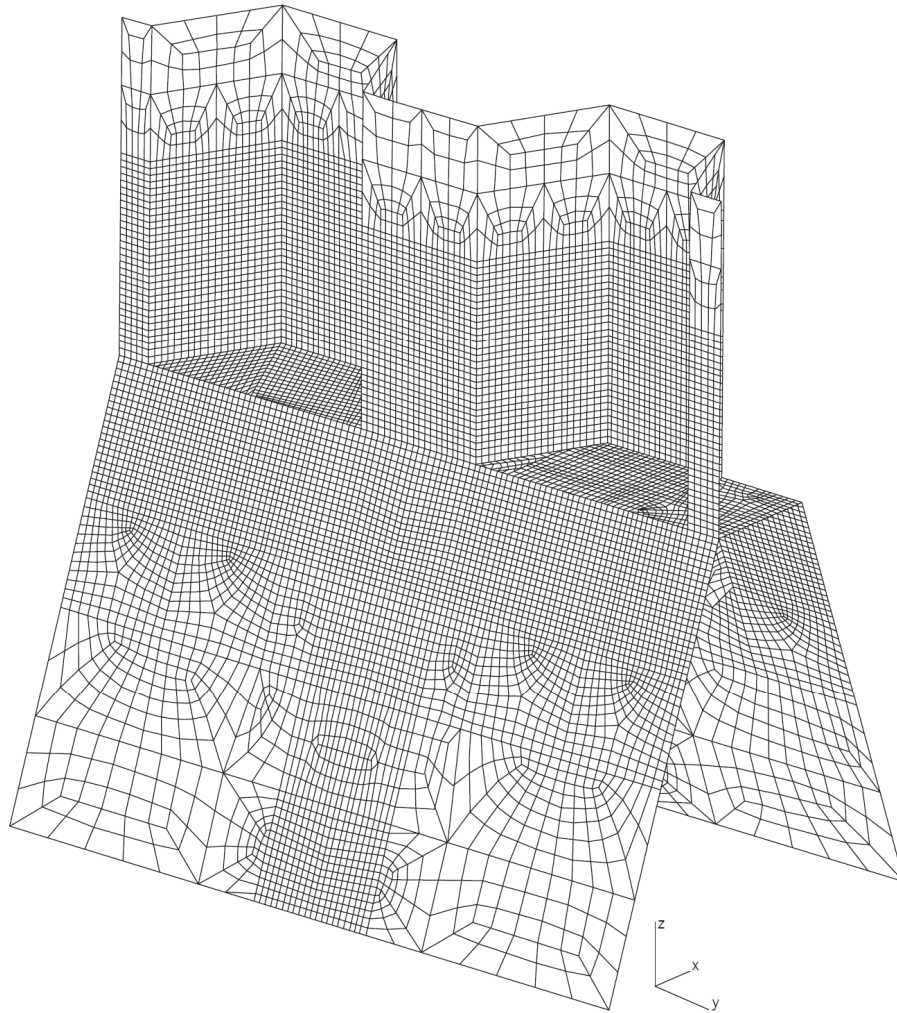
- For transverse corrugated bulkheads, the local model is to be extended transversely to the nearest diaphragm web in the lower stool on each side of the fine mesh zone (i.e. the local model covers two lower stool transverse web/diaphragm spaces). The end diaphragms need not be modelled.
- For the longitudinal corrugated bulkheads, the local model is to be extended to the nearest web frame on each side of the fine mesh zone (i.e. the local model covers two frame spaces). The end web frames need not be modelled.
- For the corrugation and lower stool connection located close to the intersection of transverse and longitudinal corrugated bulkheads, such as for product tanker, the local model is to cover the structure between the diaphragms (in transverse direction) and web frames (in longitudinal direction) closest to the detail, whichever is relevant. In addition, the local model is to be extended at least one diaphragm/ web frame outside the intersection between the transverse stool and the longitudinal stool.
- For lower stool to inner bottom connection, the connection between inner bottom, lower stool plate, diaphragm and double bottom girder, where applicable, is the centre of the fine mesh zone.

4.3.8.3 For corrugation connections, the fine mesh zone is to cover at least the corrugation flange under investigation, the adjacent corrugation webs and a further extension of 500 mm from each end of the corrugation web, i.e. the fine mesh zone covers at least four corrugation knuckles, see *Figure 4.3.8 (a)* and *Figure 4.3.8 (b)*. The mesh size within the fine mesh zone is not to be greater than 50 × 50 mm.

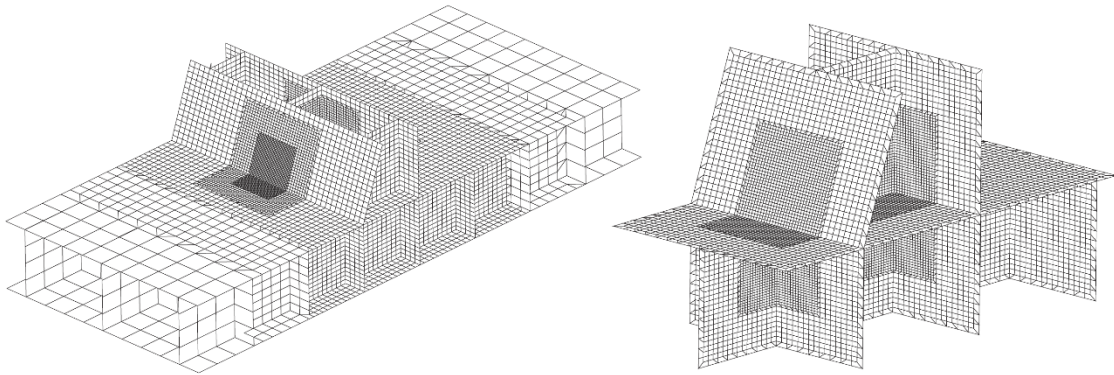


**Figure 4.3.8 (a): Example of local analysis of deck, double bottom longitudinal and adjoining transverse bulkhead vertical stiffeners**

Above figures show the extent of local model and fine mesh zone on longitudinal corrugated bulkhead connection to lower stool. Similar extent applies to transverse corrugated bulkhead. The model extents shown above are the minimum extents.

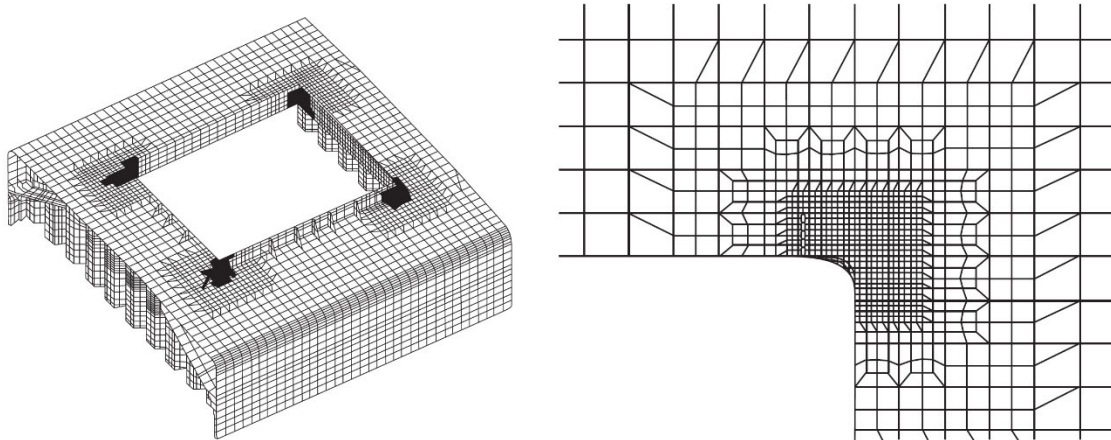


**Figure 4.3.8 (b): Example of partial local model for the analysis of connection of corrugated bulkhead and lower stool**



**Figure 4.3.8 (c): Example of partial local model for the analysis of connection of lower stool to inner bottom**

- 4.3.8.9 Diaphragm webs, brackets inside the lower stool and all stiffeners on the stool plate and diaphragm are to be modelled at their actual positions within the extent of the local model. Shell elements are to be used for modelling of diaphragm, web and flange of vertically orientated stiffeners, and brackets in the fine mesh zone.
- 4.3.8.10 Horizontally orientated stiffeners within the fine mesh zone are to be represented by either shell or beam elements.
- 4.3.8.11 FE local models for the fine mesh analysis of longitudinal bulkhead to lower stool connection and lower stool to inner bottom connection are shown in *Figure 4.3.8 (b)* and *Figure 4.3.8 (c)* respectively.
- 4.3.9 Hatch corner structures
- 4.3.9.1 In addition to the requirements of [4.3.2] to [4.3.4], the modelling requirements in this sub-section are applicable to the analysis of hatch corner structures.
- 4.3.9.2 The high stress area, such as hatch coming end bracket, the hatch end beam connection, need to be analysed by fine mesh model. The fine mesh zones cover these areas, see *Figure 4.3.9*.



**Figure 4.3.9: Example of local model for the analysis of hatch opening structures**

#### 4.4 Screening procedure

##### 4.4.1 General

4.4.1.1 Local structural details where the stress gradient changes sharply due to complex geometry, the potential stresses can be much higher than the average stress on the area of coarse mesh analysis. Such locations are to be identified through the screening procedure and fine mesh analysis is to be performed to investigate the real stress distribution over those areas.

4.4.1.2 Examples of the screening procedure of structural details are given in Appendix A.

#### 4.5 Loads and FE load combinations

##### 4.5.1 General

4.5.1.1 The fine mesh detailed stress analysis is to be carried out for all FE load combinations applied to the corresponding full ship analysis (*Section 2*) or cargo hold analysis (*Section 3*).

##### 4.5.2 Load application and boundary conditions

4.5.2.1 Where a separate local model is used for the fine mesh detailed stress analysis, the nodal displacements from the cargo hold model or full ship model are to be applied to the corresponding boundary nodes on the local model as prescribed displacements. Alternatively, equivalent nodal forces from the cargo hold model or full ship model may be applied to the boundary nodes.

4.5.2.2 Where there are nodes on the local model boundaries which are not coincident with the nodal points on the cargo tank model, it is acceptable to impose prescribed displacements on these nodes using multi-point constraints. The use of linear multi-point constraint equations connecting two neighbouring coincident nodes is considered sufficient.

4.5.2.3 All local loads, including any loads applied for hull girder bending moment and/or shear force adjustments, in way of the structure represented by the separate local finite element model are to be applied to the model.



## 4.6 Analysis criteria

### 4.6.1 Reference stress

4.6.1.1 Von Mises stress is taken as the reference stress,  $\sigma_{vm}$ , which is to be calculated based on the membrane normal and shear stresses of the shell element evaluated at the element centroid. The stresses are to be evaluated at the mid plane of the element.

### 4.6.2 Permissible stress

4.6.2.1 The maximum permissible stresses are based on the mesh size of 50 x 50 mm as specified in *Section 4*, [4.3.1] to [4.3.4]. Where a smaller mesh size is used, an area weighted von Mises stress calculated over an area equal to the specified mesh size may be used to compare with the permissible stresses. The averaging is to be based only on elements with their entire boundary located within the desired area. The average stress is to be calculated based on stresses at element centroid; stress values obtained by interpolation and/or extrapolation are not to be used. Stress averaging is not to be carried across structural discontinuities and abutting structure.

### 4.6.3 Allowable stress criteria

4.6.2.1 Verification of stress results against the allowable stress criteria is to be carried out in accordance with *Section 4*, [4.6.1] and [4.6.2]. The structural assessment is to demonstrate that the stress complies with the following criteria:

$$\lambda_f \leq \lambda_{yperm}$$

where,

$\lambda_y$  : Yield utilization factor

$$\lambda_y = \frac{\sigma_{vm}}{\sigma_y} ; \quad \text{For plate elements in general}$$

$$\lambda_y = \frac{|\sigma_{axial}|}{\sigma_y} ; \quad \text{For rod or beam elements in general}$$

$\sigma_{vm}$  : von Mises Stress in [N/mm<sup>2</sup>]

$\sigma_{axial}$  : Axial Stress in rod element [N/mm<sup>2</sup>]

$\lambda_{yperm}$  : Fine mesh permissible yield utilization factor are given in *Table 4.6.3*.

$\sigma_y$  : Nominal yield stress (considering the material factor as per IRS Rules e.g. 235/k)

Table 4.6.3: Permissible fine mesh yield utilization factor, $\lambda_{fperm}$		
Structural Member	Load components	$\lambda_{fperm}$
Elements not adjacent to weld	S	1.36 $f_f$
	S+D	1.7 $f_f$
Elements adjacent to weld	S	1.2 $f_f$
	S+D	1.5 $f_f$
<p>where,</p> <p><math>f_f</math> = fatigue factor taken as:</p> <ul style="list-style-type: none"> <li>= 1.0 in general</li> <li>= 1.2 for details where fatigue strength is verified by hot spot stresses based on very fine mesh finite element analysis</li> </ul>		

---

## Appendix A

### Screening Procedure

#### A.1 Screening Areas

A.1.1 The structural details subject to the screening procedure are checked in the following ship areas:

A.1.1.1 Within the full cargo hold region

The following structural details and areas in the cargo hold region are to be evaluated by screening:

- Openings which do not require modelling and manholes, see *Section 3*, [3.4.4.5], in way of web of primary supporting members, such as transverse web frame as indicated in *Table A.1.1 (a)* and *Table A.1.1 (b)*, horizontal stringers as indicated in *Table A.1.1 (c)*, floors and longitudinal girders in double bottom.
- Bracket toes on transverse web frame as indicated in *Table A.1.1 (a)* and *Table A.1.1 (b)* horizontal stringer and transverse plane bulkhead connected to double bottom or buttress structure specified in *Table A.1.1 (c)*.
- Heels of transverse bulkhead horizontal stringers specified in *Table A.1.1 (c)*.
- Connections of transverse lower stool to double bottom girders and longitudinal lower stool to double bottom floors as indicated in *Figure A.1.1 (a)*.
- Connection of lower hopper to transverse lower stool structure as indicated in *Figure A.1.1 (a)*.
- Connection of topside tank to inner side as indicated in *Figure A.1.1 (b)*.
- Connection of corrugation and upper supporting structure to upper stool as indicated in *Figure A.1.1 (c)*.
- Hatch corner area, such as the hatch coaming end bracket, the hatch corner and the hatch end beam connection as indicated in *Figure A.1.1 (d)*.

Within each group of the structural details having the same geometry and the same relative location inside the cargo region, the screening verification can be performed for the detail for which the yield utilisation factor,  $\lambda_y$ , is maximum

A.1.1.2 Outside mid-ship cargo hold region

The following structural details outside mid-ship cargo hold region are to be evaluated by screening:

- Hopper knuckle, as defined in *Section 4*, [4.2.2] and [4.2.3]
- Side frame end bracket, as defined in *Section 4*, [4.2.3]

- Large openings, as defined in *Section 4, [4.2.4]*
- Connections of corrugation to adjoining structure, as defined in *Section 4, [4.2.6]*
- Bracket at the heel of horizontal stringers in *Section 4, [4.2.7]*

The connections of corrugation to adjoining structure and the bracket at the heel of horizontal stringers to be screened are to be similar in its geometry, its proportion and its relative location to the corresponding detail modelled in fine mesh in the mid-ship cargo hold region.

When the connections of corrugation to adjoining structure and the bracket at the heel of horizontal stringers outside the mid-ship cargo hold region are different from the corresponding detail modelled in fine mesh in the mid-ship cargo hold region, a fine mesh analysis is to be performed for the detail located where the yield utilisation factor,  $\lambda_y$ , is maximum for structural details having the same geometry and the same relative location.

When it is deemed necessary, IRS may request a fine mesh analysis to be performed.

**Table A.1.1 (a): Screening areas of transverse web frame in oil tanker**

	Bracket toes
	Openings and manholes (shaded regions)
	Openings and manholes (unshaded regions) <div style="margin-left: 20px;">                     Screening check to be performed for openings except if:  <math>h_o/h &lt; 0.35</math> and <math>g_o &lt; 1.2</math>, and each end of the opening forms a semi-circle arc (i.e. radius of opening equal to <math>b/2</math>). This criterion does not apply to manholes which are to be evaluated by screening irrespective of size.                 </div>

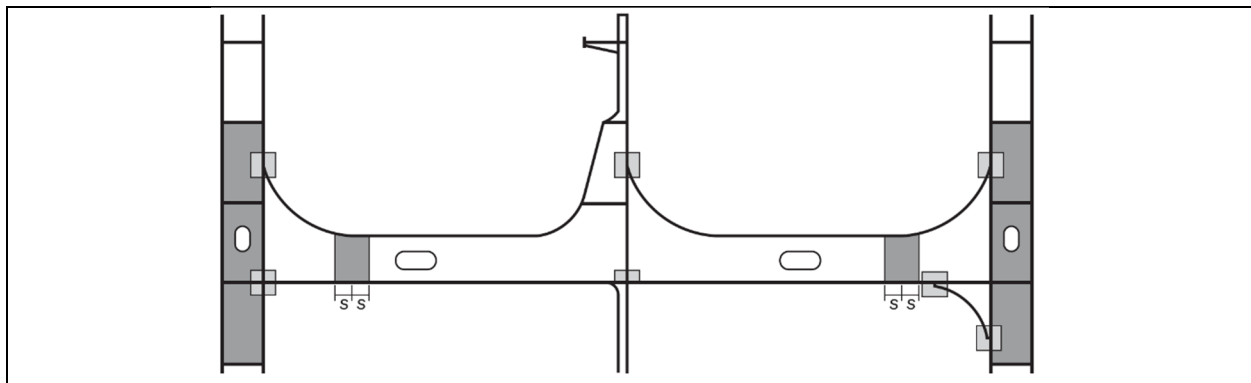
---

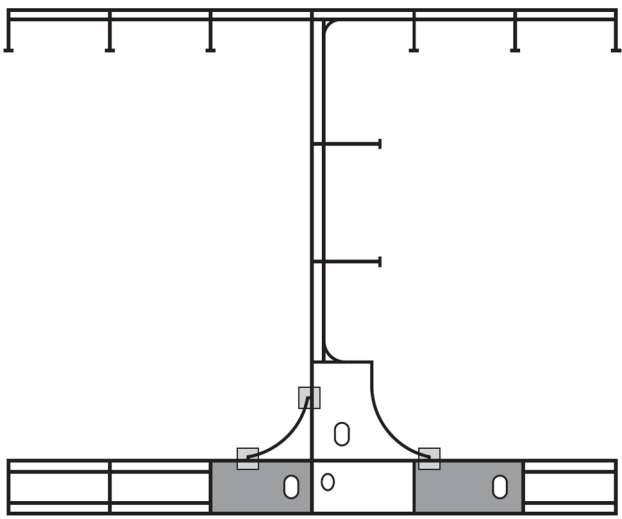



		$h_o$ , $h$ and $g_o$ is defined in Section 3, [3.4.4.5], $b$ is the smallest of the length and breadth of the opening.
--	--	---

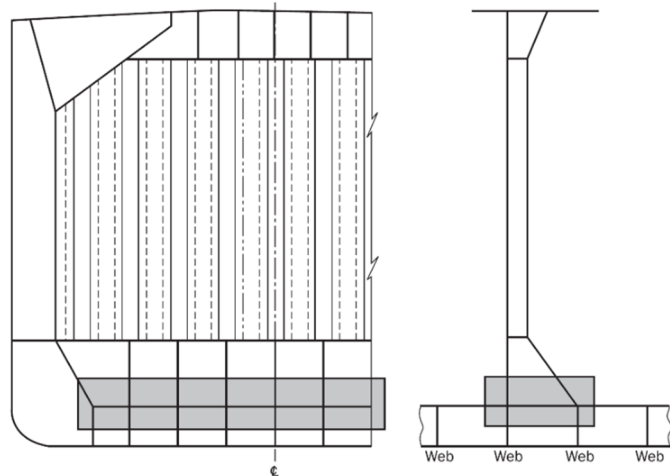
Table A.1.1 (b): Screening areas of transverse web frame in bulk carrier

	Bracket toes
	Openings and manholes (shaded regions)
	<p>Openings and manholes (unshaded regions)</p> <p>Screening check to be performed for openings except if:  <math>h_o/h &lt; 0.35</math> and <math>g_o &lt; 1.2</math>, and each end of the opening forms a semi-circle arc (i.e. radius of opening equal to <math>b/2</math>). This criterion does not apply to manholes which are to be evaluated by screening irrespective of size.</p> <p><math>h_o</math>, <math>h</math> and <math>g_o</math> is defined in Section 3, [3.4.4.5], <math>b</math> is the smallest of the length and breadth of the opening.</p>

Table A.1.1 (c): Screening areas for horizontal stringer and transverse bulkhead to double bottom connections in oil tanker



		
	Bracket toes	
	Openings and manholes (shaded regions)	
	Openings and manholes (unshaded regions)	Screening check to be performed for openings except if: $h_o/h < 0.35$ and $g_o < 1.2$ , and each end of the opening forms a semi-circle arc (i.e. radius of opening equal to $b/2$ ). This criterion does not apply to manholes which are to be evaluated by screening irrespective of size.  $h_o$ , $h$ and $g_o$ is defined in Section 3, [3.4.4.5], $b$ is the smallest of the length and breadth of the opening.



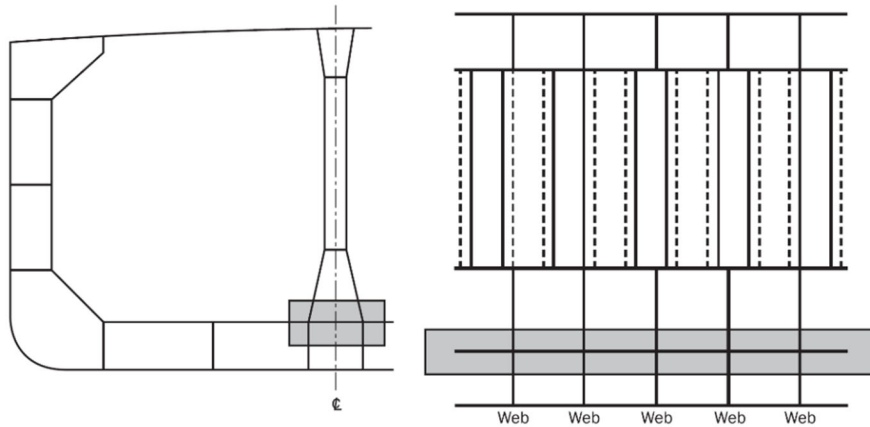


Figure A.1.1 (a): Screening areas at connections of lower stool to inner bottom and hopper tank

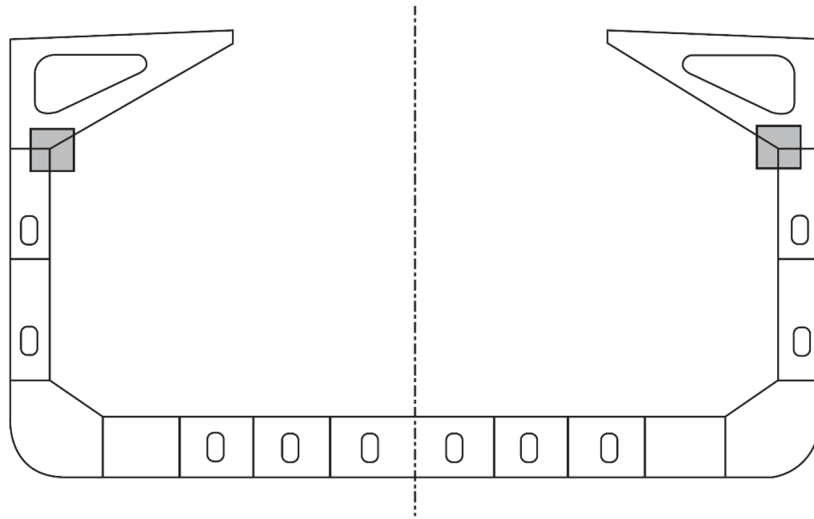


Figure A.1.1 (b): Screening areas at connections of topside tank to inner side

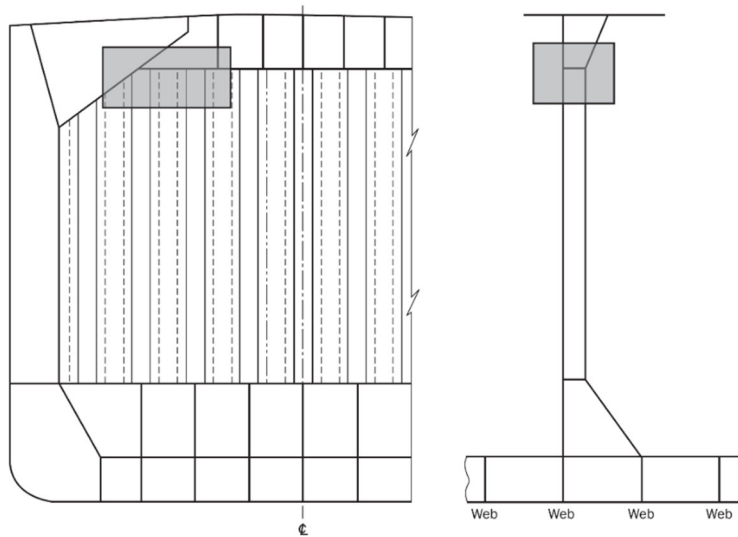


Figure A.1.1 (c): Screening areas at connection of corrugation and upper supporting structure to upper stool



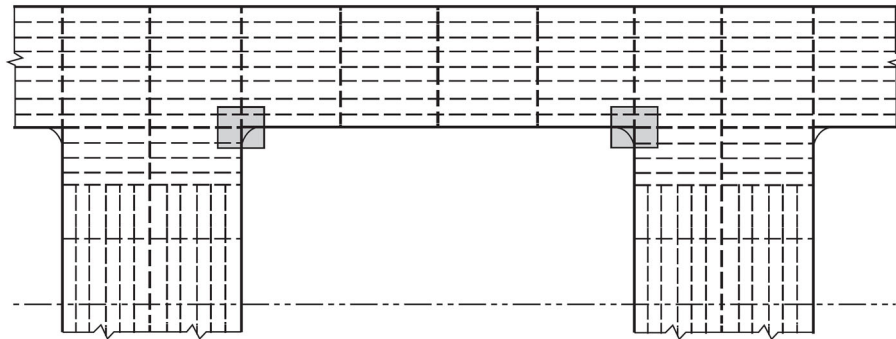


Figure A.1.1 (d): Screening areas at hatch corner in bulk carrier

**A.2 Screening criteria**

A.2.1 Screening factors and permissible screening factors

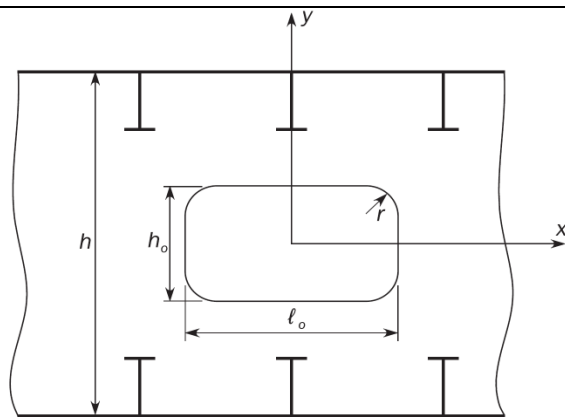
A.2.1.1 The screening factors,  $\lambda_{sc}$  and the permissible screening factors,  $\lambda_{scperm}$ , are given in *Table A.2.1 (a)* for the screening areas defined in [A.1].

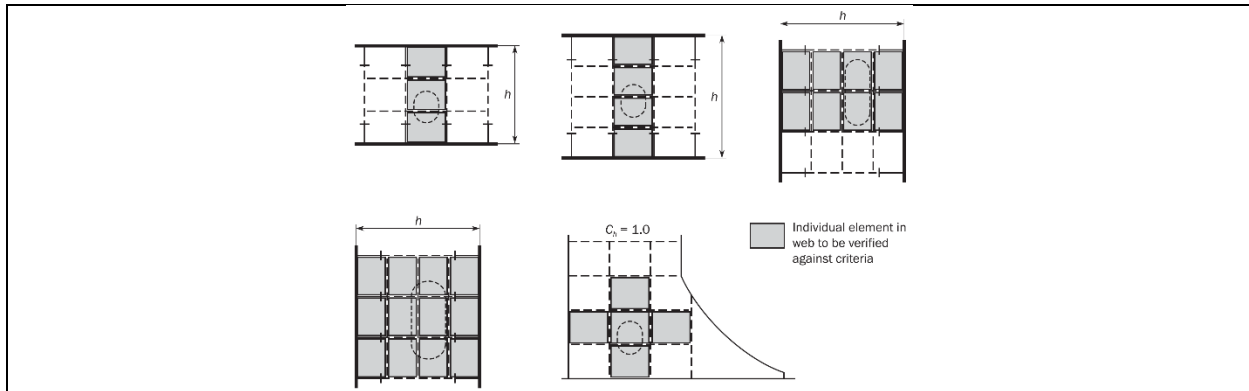
Table A.2.1 (a): Screening factors and permissible screening factors			
Type of Details	Screening factors, $\lambda_{sc}$	Permissible screening factors, $\lambda_{scperm}$	
		S+D	S
Within the whole cargo hold region		S+D	S
Openings for which their geometry is not required to be represented in the cargo hold model in accordance with [3.4.4.5], in way of webs of primary supporting members, such as transverse web frame as indicated in Table A.1.1 (a) and Table A.1.1 (b), horizontal stringers as indicated in Table A.1.1 (c), floors and longitudinal girders in double bottom.	Table A.2.1 (b)	1.70	1.36
Manholes (2)	$\lambda_y$	0.85 $\lambda_{yperm}$	
Bracket toes on transverse web frames as indicated in Table A.1.1 (a) and Table A.1.1 (b), horizontal stringers and transverse plane bulkhead to double bottom connection or buttress structure specified in Table A.1.1 (c).	Table A.2.1 (c)	1.50	1.20
Heels of transverse bulkhead horizontal stringers specified in Table A.1.1 (c).	Table A.2.2	1.50	1.20

Connections of transverse lower stool to double bottom girders and longitudinal lower stool to double bottom floors as indicated in Figure A.1.1 (a). The connection of lower hopper to transverse lower stool structure as indicated in Figure A.1.1 (a). The connection of topside tank to inner side as indicated in Figure A.1.1 (b). The connection of corrugation and upper supporting structure to upper stool as indicated in Figure A.1.1 (c).	$\lambda_y$	0.75 $\lambda_{yperm}$	
Hatch corner area	$\lambda_y$	0.95 $\lambda_{yperm}$	
Outside mid-ship cargo hold region			
Hopper knuckle	$\lambda_y$	0.65 $\lambda_{yperm}$	
Side frame end bracket		0.85 $\lambda_{yperm}$	
Large openings (2)		0.85 $\lambda_{yperm}$	
Connections of corrugation to adjoining structure and bracket at the heel of horizontal stringer	$\lambda_{sc} = \frac{K_{sc}\sigma_c}{\sigma_Y}$ (1)	1.5 $f_f$	1.2 $f_f$
<p>where,</p> <p><math>\lambda_y</math> : Coarse mesh yield utilisation factor, as defined in <i>Section 3, [3.9.3]</i></p> <p><math>\lambda_{yperm}</math> : Coarse mesh permissible yield utilisation factor, as defined in <i>Section 3, [3.9.3]</i></p> <p><math>K_{sc}</math> : Screening stress concentration factor, taken as:</p> $K_{SC} = \frac{\sigma_{FM}}{\sigma_{CM}}$ <p><math>\sigma_{FM}</math> : Von Mises fine mesh stress [N/mm<sup>2</sup>] for the considered detail calculated in the mid-ship cargo hold region according to <i>Section 4</i>.</p> <p><math>\sigma_{CM}</math> : Von Mises coarse mesh stress [N/mm<sup>2</sup>] for the considered detail calculated in the mid-ship cargo hold region according to <i>Section 4</i>.</p> <p><math>\sigma_c</math> : Von Mises coarse mesh stress [N/mm<sup>2</sup>] for the area in way of considered detail.</p> <p><math>f_f</math> : Fatigue factor defined in <i>Section 4, [4.6]</i></p> <p><b>NOTE:</b></p> <p>(1) For each screened detail, <math>\sigma_{FM}</math> and <math>\sigma_{CM}</math> are to be taken from the corresponding elements in the same plane position.</p> <p>(2) The representative element which has maximum yield utilisation factor around the manhole and the large opening is to be verified against criterion</p>			

**Table A.2.1 (b): Screening factor for openings in primary supporting members**

$\lambda_{sc}$	: Screening factor taken as  $\lambda_{sc} = 0.85C_h \left(  \sigma_x + \sigma_y  + \left( 2 + \left( \frac{l_o}{2r} \right)^{0.74} + \left( \frac{h_o}{2r} \right)^{0.74} \right)  \tau_{xy}  \right) \frac{k}{235}$
$C_h$	: Coefficient taken as <sup>(2)</sup> :  <ul style="list-style-type: none"> <li>For opening in web of PSM.  <math display="block">C_h = 1.0 - 0.23 \left( \frac{h_o}{h} \right) + 2.12 \left( \frac{h_o}{h} \right)^2</math></li> <li>For opening in web of main bracket and buttress (see figures below).  <math display="block">C_h = 1.0</math></li> </ul>
$r$	: Radius of opening [mm]
$h_o$	: Height of opening parallel to depth of web [mm]
$l_o$	: Length of opening parallel to girder web direction [mm]
$h$	: Height of web of girder in way of opening [mm]
$\sigma_x$	: Axial stress in element x-direction determined from cargo hold FE analysis according to the coordinate system shown [N/mm <sup>2</sup> ].
$\sigma_y$	: Axial stress in element y-direction determined from cargo hold FE analysis according to the coordinate system shown [N/mm <sup>2</sup> ].
$\tau_{xy}$	: Element shear stress determined from cargo hold FE analysis <sup>(1)</sup> [N/mm <sup>2</sup> ].

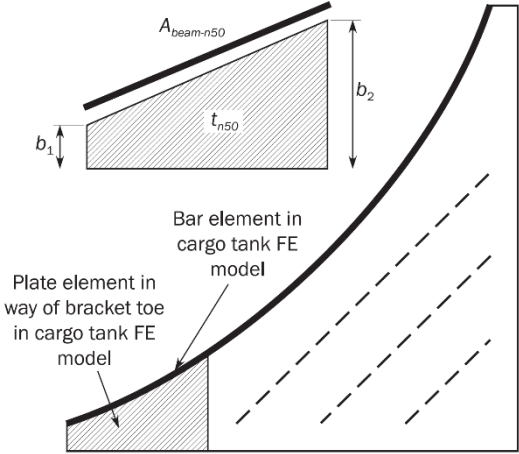


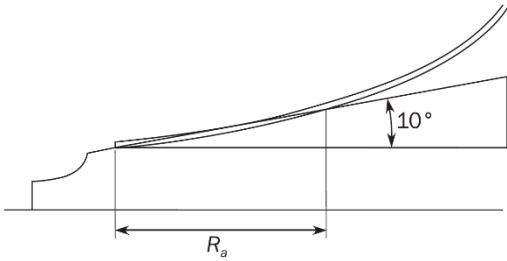
**NOTE:**

- (1) The element shear stress is to be adjusted using the formula given in *Section 3*, [3.9.3.8] prior to the evaluation of yield utilisation factor for verification against the screening criteria.
- (2) Where the geometry of the opening is required to be modelled in accordance with *Section 3*, [3.4.4.5], fine mesh FE analysis is to be carried out to determine the stress level and the screening criteria are not applicable.

**Table A.2.1 (c): Screening factor for bracket toes of primary supporting members**

$\lambda_{SC}$	: Screening factor taken as: $\lambda_{SC} = C_a \left( 0.68 \left( \frac{b_2}{b_1} \right)^{0.5} \sigma_{vm} + 0.5 \left( \frac{A_{beam}}{b_1 t} \right)^{0.5}  \sigma_{beam}  \right) \frac{k}{235}$
$C_a$	: Coefficient taken as: $C_a = 1.0 - 0.2 \left( \frac{R_a}{1400} \right)^2$
$b_1, b_2$	: Height of shell element in way of bracket toe in cargo hold FE model [mm]
$A_{beam-n50}$	: Sectional area of beam or rod element in cargo hold FE model representing the face plate of bracket [mm <sup>2</sup> ]
$\sigma_{beam}$	: Beam or rod element axial stress determined from cargo hold FE analysis [N/mm <sup>2</sup> ]
$\sigma_{vm}$	: von Mises stress of shell element in way of bracket toe determined from cargo hold FE analysis [N/mm <sup>2</sup> ]
$t_{n50}$	: Net thickness of shell element in way of bracket toe [mm]
$R_a$	: Leg length [mm] not to be taken as greater than 1400 [mm]





**A.2.2 Screening criteria**

A.2.2.1 Stresses in areas defined in [A.1], calculated for all applicable FE load combinations given in Section 4 [4.4] are to be checked against the following screening criteria:

$$\lambda_{sc} \leq \lambda_{scperm}$$

where:

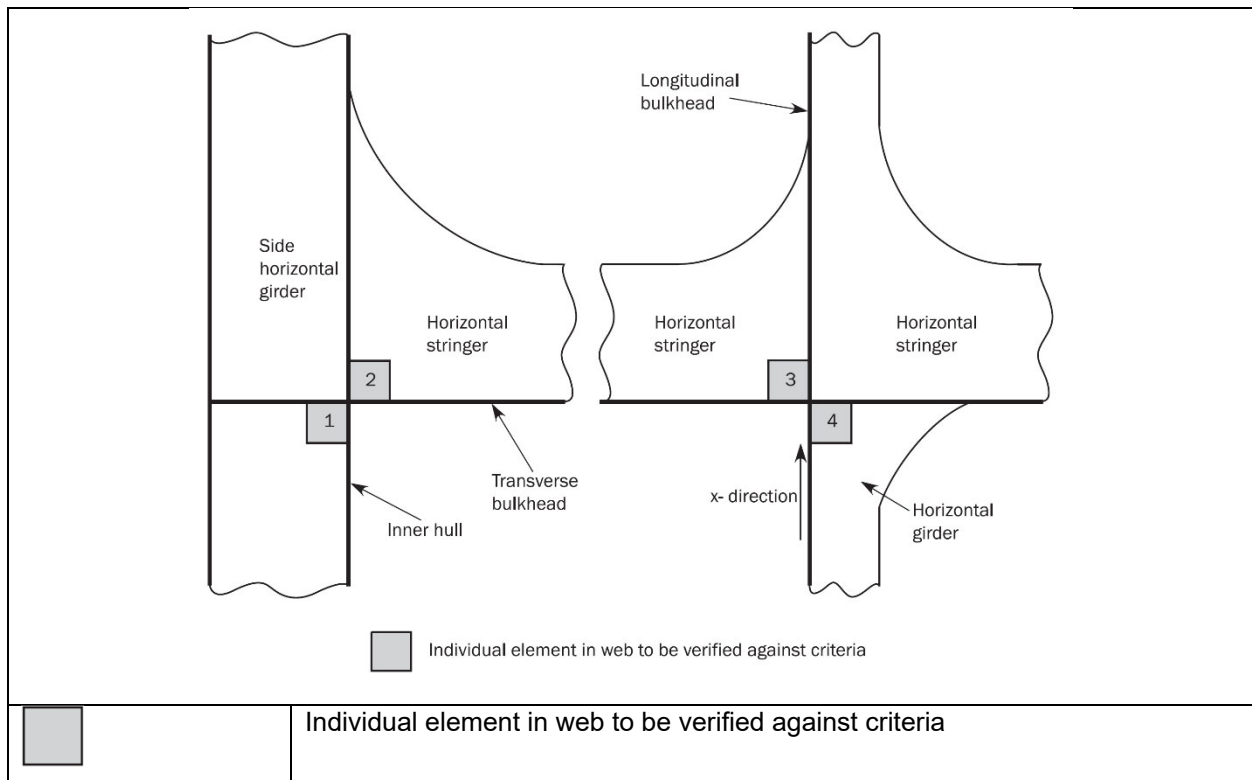
$\lambda_{sc}$  : Screening factor defined in [A.2]

$\lambda_{scperm}$  : Permissible screening factor defined in [A.2]

Where the screening criteria are not met, fine mesh analysis of the corresponding structural detail is required and to be performed according to requirements given in *Section 4*, [4.3], under the FE load combination defined in *Section 4*, [4.4] and to comply the criteria given in *Section 4*, [4.6].

**Table A.2.2: Screening factor for heels of transverse bulkhead horizontal stringers**

$\lambda_{sc}$	: Screening factor taken as: <ul style="list-style-type: none"> <li>• For heels at side horizontal girder and transverse bulkhead horizontal stringer, at the locations 1, 2 and 3 in figure below: <math display="block">\lambda_{sc} = 1.67 \sigma_{vm} \frac{k}{235}</math> </li> <li>• For heel at longitudinal bulkhead horizontal stringer, at the location 4 in figure below: <math display="block">\lambda_{sc} = 3.2  \sigma_x  \frac{k}{235}</math> </li> </ul>
$\sigma_x$	: Axial stress in element x-direction determined from cargo hold FE analysis in accordance with the coordinate system shown [N/mm <sup>2</sup> ].
$\sigma_{vm}$	: von Mises stress of shell element in way of heel determined from cargo hold FE analysis [N/mm <sup>2</sup> ].



\*\*\*End of Guidelines\*\*\*