

INDIAN REGISTER OF SHIPPING

CLASSIFICATION NOTES

Guidelines for Non- Destructive Examination of Hull and Machinery Steel Forgings

January 2005



IRCLASS
Indian Register of Shipping

CLASSIFICATION NOTES

Guidelines for Non-Destructive Examination of Hull and Machinery Steel Forgings

January 2005

Contents

Sections

- 1. General**
 - 1.1 Scope

- 2. Surface Inspections**
 - 2.1 General
 - 2.2 Products
 - 2.3 Zones for Surface Inspections
 - 2.4 Surface Condition
 - 2.5 Surface Inspection
 - 2.6 Acceptance Criteria and Rectification of Defects
 - 2.7 Record

- 3. Volumetric Inspection**
 - 3.1 General
 - 3.2 Products
 - 3.3 Zones for Volumetric Inspection
 - 3.4 Surface Condition
 - 3.5 Acceptance Criteria
 - 3.6 Record

1. General

1.1 Scope

- 1.1.1 These guidelines complement the requirements for hull and machinery steel forgings given in IRS Rules Pt.2, Ch.5 “Steel Forgings” and Pt.4, Ch.4, Sec.4 “Oil Engines” Table 4.3.1 “Parts of internal combustion engines for which non-destructive tests are required” and contain general guidance for the non-destructive examination methods, the extent of examination and the minimum recommended quality levels to be complied with unless otherwise approved or specified.
- 1.1.2 This document contains guidelines on “Surface Inspections” (Section 2) by visual examination, magnetic particle testing and liquid penetrant testing and volumetric Inspection” (Section 3) by ultrasonic testing.
- 1.1.3 For steel forgings (e.g. components for couplings, gears, boilers and pressure vessels) other than those specified in these guidelines, the requirements in these guidelines may apply correspondingly considering their materials, kinds, shapes and stress conditions being subjected.
- 1.1.4 Forgings should be examined in the final delivery condition. For specific requirements see paragraphs 2.5.2 and 3.4.2.
- 1.1.5 Where intermediate inspections have been performed the manufacturer shall furnish a documentation of the results upon the request of the Surveyor.
- 1.1.6 Where a forging is supplied in semi-finished condition, the manufacturer shall take into consideration the quality level of final finished machined components.

2. Surface Inspections

2.1 General

- 2.1.1 Surface inspections are to be carried out by visual examination and magnetic particle testing or liquid penetrant testing.
- 2.1.2 The testing procedures, apparatus and conditions of magnetic particle testing and liquid penetrant testing are to comply with the recognised national or international standards.
- 2.1.3 Personnel engaged in visual examination is to have sufficient knowledge and experience. Personnel engaged in magnetic particle testing or liquid penetrant testing is to be qualified in accordance with the Society’s Rules. The qualification is to be verified by certificates.

2.2 Products

2.2.1 The steel forgings are to be subjected to a 100% visual examination by the Surveyor. For mass produced forgings the extent of examination will be specially considered in each case.

2.2.2 Surface inspections by magnetic particle and/or liquid penetrant methods generally apply to the following steel forgings manufactured at the approved works:

- 1) crankshafts with minimum crankpin diameter not less than 100 mm;
- 2) propeller shafts, intermediate shafts, thrust shafts, rudder stocks and rudder shafts with minimum diameter not less than 100 mm;
- 3) connecting rods, piston rods and crosshead with minimum diameter not less than 75 mm or equivalent cross section;
- 4) bolts with minimum diameter not less than 50 mm, which are subjected to dynamic stresses such as cylinder cover bolts, tie rods, crankpin bolts, main bearing bolts, propeller blade fastening bolts.

Note : 1) Any forgings supplied by the traders are to be subjected to UT regardless of their sizes.

2) Forgings of diameters greater than 250 [mm] or equivalent cross section are to be subjected to UT and either magnetic particle or liquid penetrant test. For additional requirements for ultrasonic testing of forgings for specific items, refer to 3.2.1.

2.3 Zones for Surface Inspections

2.3.1 Magnetic particle or where permitted liquid penetrant testing shall be carried out in the zones I and II as indicated in Figures 1 to 4.

2.4 Surface Conditions

2.4.1 The surfaces of forgings to be examined are to be free from scale, dirt, grease or paint. If the testing performed in as-forged condition, only if it can be ensured that the roughness / forge mark do not prevent transmission of ultrasound within the material.

2.5 Surface Inspection

2.5.1 Where indicated by Figures 1 to 4, magnetic particle inspection will be carried out with the following exceptions, when liquid penetrant testing will be permitted:

- austenitic stainless steels;
- interpretation of open visual or magnetic particle indications;
- at the instruction of the Surveyor.

2.5.2 Unless otherwise specified in the order, the magnetic particle test shall be performed on a forging in the final machined surface condition and final thermally treated condition or within 0.3 mm of the final machined surface condition for AC techniques (0.8 mm for DC techniques).

2.5.3 Unless otherwise agreed, the surface inspection is to be carried out in the presence of the Surveyor. The surface inspection is to be carried out before the shrink fitting, where applicable.

2.5.4 For magnetic particle testing, attention is to be paid to the contact between the forging and the clamping devices of stationary magnetization benches in order to avoid local overheating or burning damage in its surface. Prods shall not be permitted on finished machined items.

2.5.5 When indications were detected as a result of the surface inspection, acceptance or rejection is to be decided in accordance with clause 2.6.

2.6 Acceptance Criteria and Rectification of Defects

2.6.1 Acceptance Criteria Visual Inspection

All forgings are to be free of cracks, crack-like indications, laps, seams, folds or other injurious indications. At the request of the Surveyor, additional magnetic particle, liquid penetrant and ultrasonic testing may be required for a more detailed evaluation of surface irregularities.

The bores of hollow propeller shafts are to be visually examined for imperfections uncovered by the machining operation. Machining marks are to be ground to a smooth profile.

2.6.2 Acceptance Criteria Magnetic Particle Testing and Liquid Penetrant Testing

2.6.2.1 The following definitions relevant to indications apply:

Linear indication	an indication in which the length is at least three times the width;
Nonlinear indication	an indication of circular or elliptical shape with a length less than three times the width;
Aligned indication	three or more indications in a line, separated by 2 mm or less edge-to-edge;
Open indication	an indication visible after removal of the magnetic particles or that can be detected by the use of contrast dye penetrant;
Non-open indication	an indication that is not visually detectable after removal of the magnetic particles or that cannot be detected by the use of contrast dye penetrant;
Relevant indication	an indication that is caused by a condition or type of discontinuity that requires evaluation. Only indications which have any dimension greater than 1.5 mm shall be considered relevant.

2.6.2.2 For the purpose of evaluating indications, the surface is to be divided into reference areas of 225 [cm²]. The area shall be taken in the most unfavourable location relative to the indication being evaluated.

2.6.2.3 The allowable number and size of indications in the reference area is given in Table 1 for crankshaft forgings and in Table 2 for other forgings, respectively. Cracks are not acceptable. Irrespective of the results of non-destructive examination, the Surveyor may reject the forging if the total number of indications is excessive.

Table 1 : Crankshaft forgings : Allowable number and size of indications in a reference area of 225 [cm²]				
Inspection Zone	Max. number of indications	Type of indication	Max. number for each type	Max. dimension [mm]
I (critical fillet area)	0	Linear Nonlinear Aligned	0 0 0	- - -
II (important fillet area)	3	Linear Nonlinear Aligned	0 3 0	- 3.0 -
III (journal surfaces)	3	Linear Nonlinear Aligned	0 3 0	- 5.0 -

Table 2 : Steel forgings excluding crankshaft forgings : Allowable number and size of indications in a reference area of 225 [cm²]

Inspection Zone	Max. number of indications	Type of indication	Max. number for each type	Max. dimension [mm]
I	3	Linear	0 ¹⁾	-
		Nonlinear	3	3.0
		Aligned	0 ¹⁾	-
II	10	Linear	3 ¹⁾	3.0
		Nonlinear	7	5.0
		Aligned	3 ¹⁾	3.0
<p>Note:</p> <p>1) Linear or aligned indications are not permitted on bolts, which receive a direct fluctuating load, e.g. main bearing bolts, connecting rod bolts, crosshead bearing bolts, cylinder cover bolts.</p>				

2.6.3 Rectification of Defects

2.6.3.1 Defects and unacceptable indications must be rectified as indicated below and detailed in 2.6.3.2 thru 2.6.3.6.

- a) Defective parts of material may be removed by grinding or by chipping and grinding. All grooves shall have a bottom radius of approximately three times the groove depth and should be smoothly blended to the surface area with a finish equal to the adjacent surface.
- b) To depress is to flatten or relieve the edges of a non-open indication with a fine pointed abrasive stone with the restriction that the depth beneath the original surface shall be 0.08 [mm] minimum to 0.25 [mm] maximum and that the depressions be blended into the bearing surface. A depressed area is not considered a groove and is made only to prevent galling of bearings.
- c) Non-open indications evaluated as segregation need not be rectified.
- d) Complete removal of the defect is to be proved by magnetic particle testing or penetrant testing, as appropriate.
- e) Repair welding is not permitted for crankshafts. Repair welding of other forgings is subjected to prior approval of IRS.

2.6.3.2 Zone I in crankshaft forgings

Neither indications nor repair are permitted in this zone.

2.6.3.3 Zone II in crankshaft forgings

Indications must be removed by grinding to a depth no greater than 1.5 [mm].

Indications detected in the journal bearing surfaces must be removed by grinding to a depth to greater than 3.0 [mm]. The total ground area shall be less than 1% of the total bearing surface area concerned.

Non-open indications, except those evaluated as segregation shall be depressed but need not be removed.

2.6.3.4 Zone I in other forgings

Indications must be removed by grinding to a depth no greater than 1.5 [mm]. However, grinding is not permitted in way of finished machined threads.

2.6.3.5 Zone II in other forgings

Indications must be removed by grinding to a depth no greater than 2% of the diameter or 4.0 [mm], whichever is smaller.

2.6.3.6 Zones other than I and II in forgings

Defects detected by visual inspection must be removed by grinding to a depth no greater than 5% of the diameter or 10 [mm], whichever is smaller. The total ground area shall be less than 2% of the forging surface area.

2.7 Record

2.7.1 Test results of surface inspections are to be recorded at least with the following items:

- 1) Date of testing;
- 2) Names and qualification level of inspection personnel;
- 3) Kind of testing method;
 - for liquid penetrant testing : test media combination
 - for magnetic particle testing : method of magnetizing, test media and magnetic field strength
- 4) Kind of product;
- 5) Product number for identification;
- 6) Grade of steel;
- 7) Heat treatment;

- 8) Stage of testing;
- 9) Position (zone) of testing;
- 10) Surface condition;
- 11) Test standards used;
- 12) Testing condition;
- 13) Results;
- 14) Statement of acceptance / non-acceptance;
- 15) Details of weld repair including sketch.

3. Volumetric Inspection

3.1 General

- 3.1.1 Volumetric inspection in these guidelines is to be carried out by ultrasonic testing using the contact method with straight beam and/or angle beam technique.
- 3.1.2 The testing procedures, apparatus and conditions of ultrasonic testing are to comply with the recognized national or international standards. Generally the DGS (distance-gain-size) procedure is to be applied using straight beam probes and/or angle beam probes with 2 to 4 MHz and inspection should be carried out using a twin crystal 0° probe for near surface scans (25 mm) plus 0° probe for the remaining volume. Fillet radii should be examined using 45°, 60° or 70° probes.
- 3.1.3 Personnel engaged in ultrasonic testing is to be qualified to Level-II in accordance with the SNT-TC-1A of ASTN/ISNT.

3.2 Products

- 3.2.1 Volumetric inspections by ultrasonic testing generally apply to the following steel forgings:
 - 1) crankshaft with minimum crankpin diameter not less than 150 [mm];
 - 2) propeller shafts, intermediate shafts, thrust shafts and rudder stocks with minimum diameter not less than 200 [mm];
 - 3) connecting rods, piston rods and crosshead with minimum diameter not less than 200 [mm] or equivalent cross section.

Note : The requirements given in 2.2 are applicable in this case also.

3.3 Zones for Volumetric Inspection

- 3.3.1 Ultrasonic testing shall be carried out in the zones I to III as indicated in Figures 5 to 8. Areas may be upgraded to a higher zone at the discretion of the Surveyors.

3.4 Surface Condition

3.4.1 The surfaces of forgings to be examined are to be such that adequate coupling can be established between the probe and the forging and that excessive wear of the probe can be avoided. The surfaces are to be free from scale, dirt, grease or paint.

3.4.2 The ultrasonic testing is to be carried out after the steel forgings have been machined to a condition suitable for this type of testing and after the final heat treatment, but prior to the drilling of the oil bores and prior to surface hardening. Black forgings shall be inspected after removal of the oxide scale by either flame descaling or shot blasting methods.

3.5 Acceptance Criteria

3.5.1 Acceptance criteria of volumetric inspection by ultrasonic testing are shown in Tables 3 and 4.

3.6 Record

3.6.1 Test results of volumetric inspection are to be recorded at least with the following items:

- 1) Date of testing;
- 2) Names and qualification level of inspection personnel;
- 3) Kind of testing method;
- 4) Kind of product;
- 5) Product number for identification;
- 6) Grade of steel;
- 7) Heat treatment;
- 8) Stage of testing;
- 9) Position (zone) of testing;
- 10) Surface condition;
- 11) Test standards used;
- 12) Testing condition;
- 13) Results;
- 14) Statement of acceptance / non-acceptance.

Table 3 : Acceptance criteria for crankshafts				
Type of Forging	Zone	Allowable disc shape according to DGS¹⁾	Allowable length of indication	Allowable distance between two indications²⁾
Crank shaft	I	$d \leq 0.5 \text{ mm}$	-	-
	II	$d \leq 2.0 \text{ mm}$	$\leq 10 \text{ mm}$	$\geq 20 \text{ mm}$
	III	$d \leq 4.0 \text{ mm}$	$\leq 15 \text{ mm}$	$\geq 20 \text{ mm}$
<p>Notes:</p> <p>1) DGS : distance-gain-size</p> <p>2) In case of accumulations of two or more isolated indications which are subjected to registration the minimum distance between two neighboring indications must be at least the length of the bigger indication.</p> <p>This applies as well to the distance in axial direction as to the distance in depth.</p> <p>Isolated indications with less distances are to be determined as one single indication.</p>				

Table 4 : Acceptance criteria for shafts and machinery components				
Type of Forging	Zone	Allowable disc shape according to DGS¹⁾²⁾	Allowable length of indication	Allowable distance between two indications³⁾
Propeller shaft intermediate shaft	II	Outer : $d \leq 10 \text{ mm}$	$\leq 10 \text{ mm}$	$\geq 20 \text{ mm}$
		Inner : $d \leq 4 \text{ mm}$	$\leq 15 \text{ mm}$	$\geq 20 \text{ mm}$
Thrust shaft Rudder stock	III	Outer : $d \leq 3 \text{ mm}$	$\leq 10 \text{ mm}$	$\geq 20 \text{ mm}$
		Inner : $d \leq 6 \text{ mm}$	$\leq 15 \text{ mm}$	$\geq 20 \text{ mm}$
Connecting rod Piston rod Crosshead	II	$d \leq 2 \text{ mm}$	$\leq 10 \text{ mm}$	$\geq 20 \text{ mm}$
	III	$d \leq 4 \text{ mm}$	$\leq 10 \text{ mm}$	$\geq 20 \text{ mm}$

Table 4 (Contd.)

Notes:

- 1) DGS : distance-gain-size
- 2) Outer part means the part beyond one third of the shaft radius from the center, the inner part means the remaining core area.
- 3) In case of accumulations of two or more isolated indications which are subjected to registration the minimum distance between two neighboring indications must be at least the length of the bigger indication.

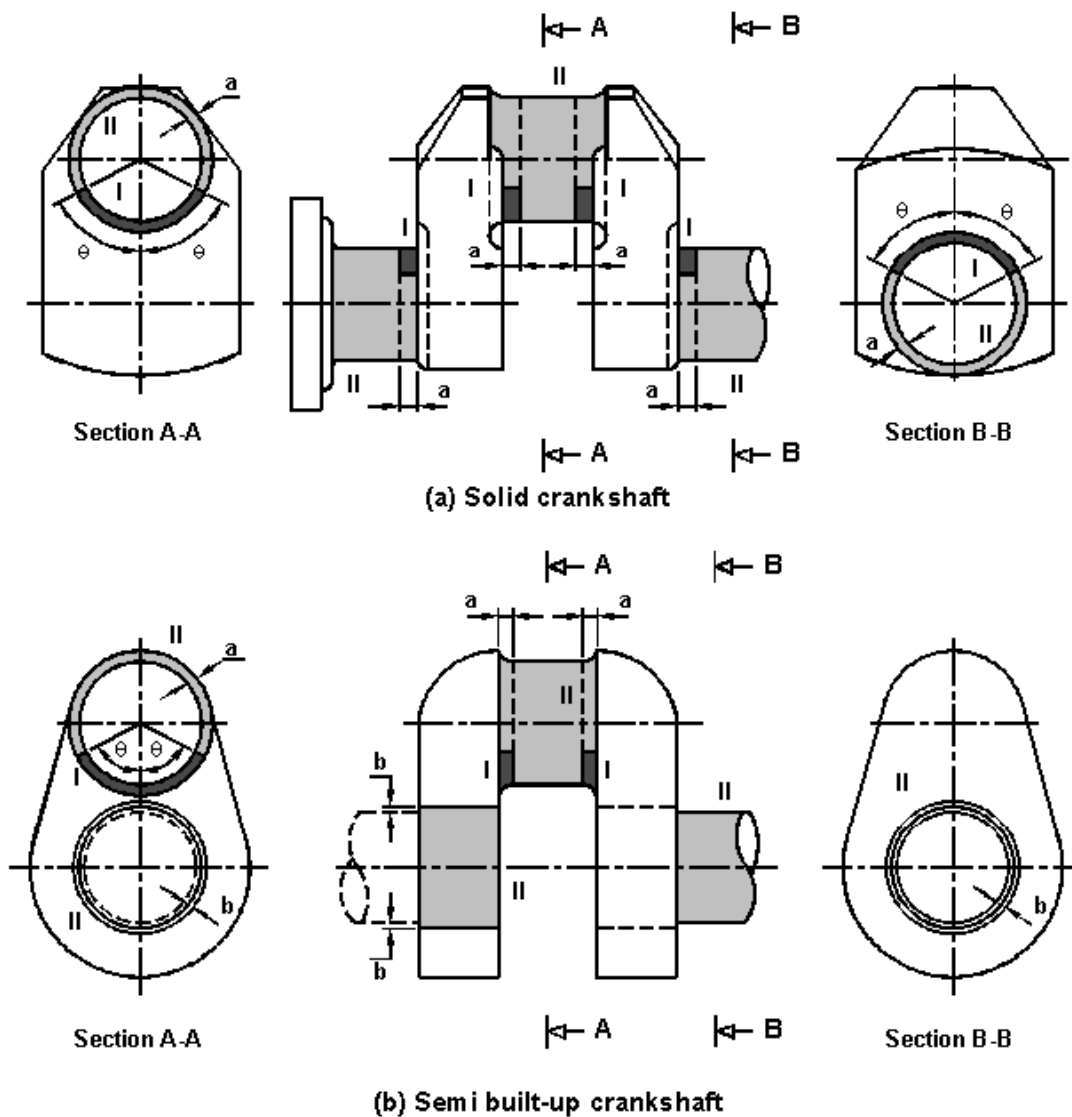

Notes :

1. Where the crankpin or journal has oil holes, the circumferential surface of the oil holes are to be treated as Zone I (See the figure in the right.)
2. In the above figure, 'θ', 'a' and 'b' mean :
 $\theta = 60^\circ$
 $a = 1.5 r$
 $b = 0.05 d$ (: circumferential surfaces of shrinkage fit)
 where,
 r = fillet radius
 d – journal diameter
3. Identification of the Zones (Similar in Figs. 1 thru 4) :

- : Zone I
- : Zone II

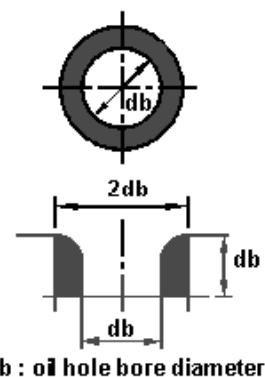
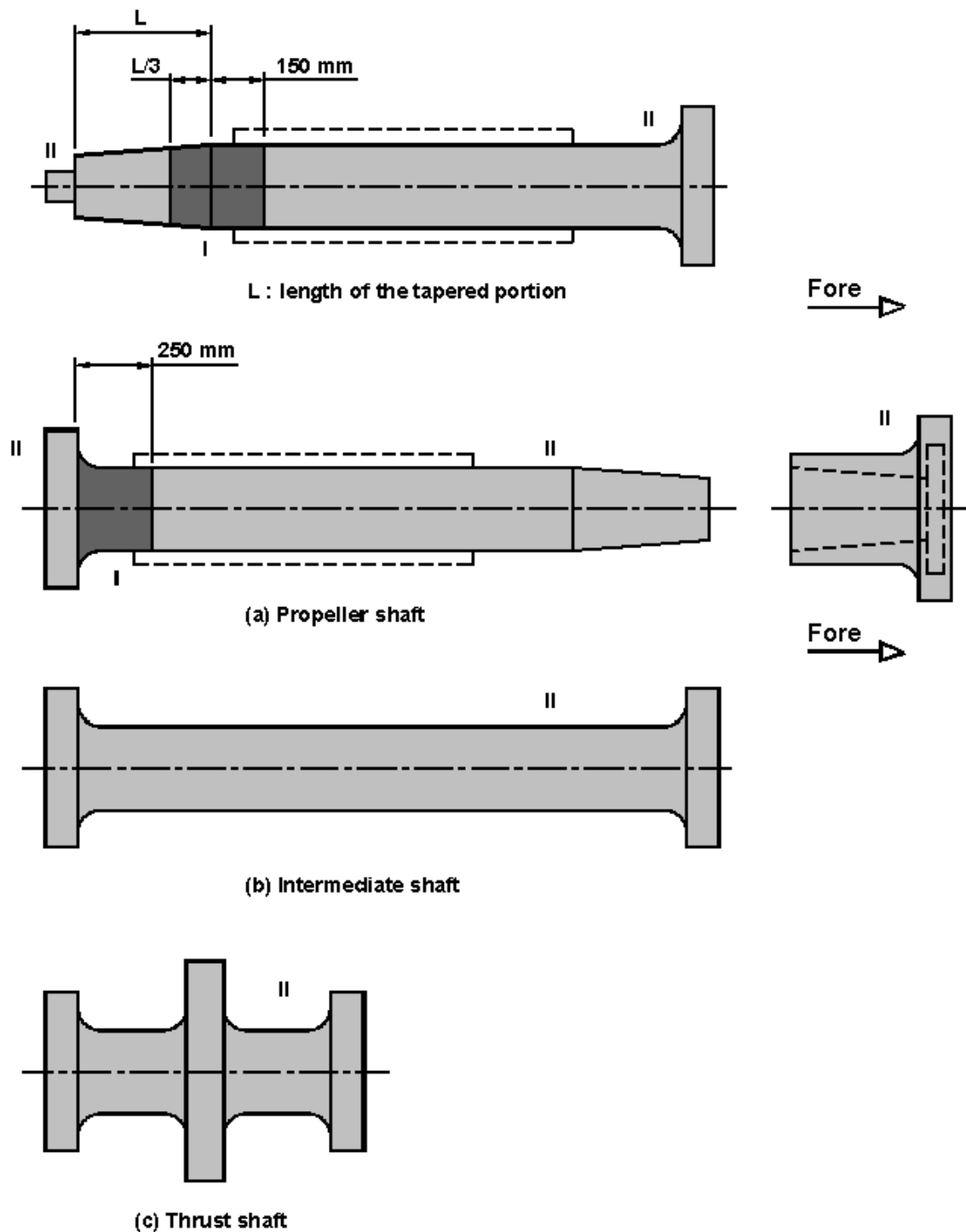

Fig.1 : Zones for magnetic particle/ liquid penetrant testing on crankshafts



Notes :

For propeller shaft, intermediate shafts and thrust shafts, all areas with stress raisers such as radial holes, slots and key ways are to be treated as Zone I.

Fig. 2 : Zones for magnetic particle / liquid penetrant testing on shafts

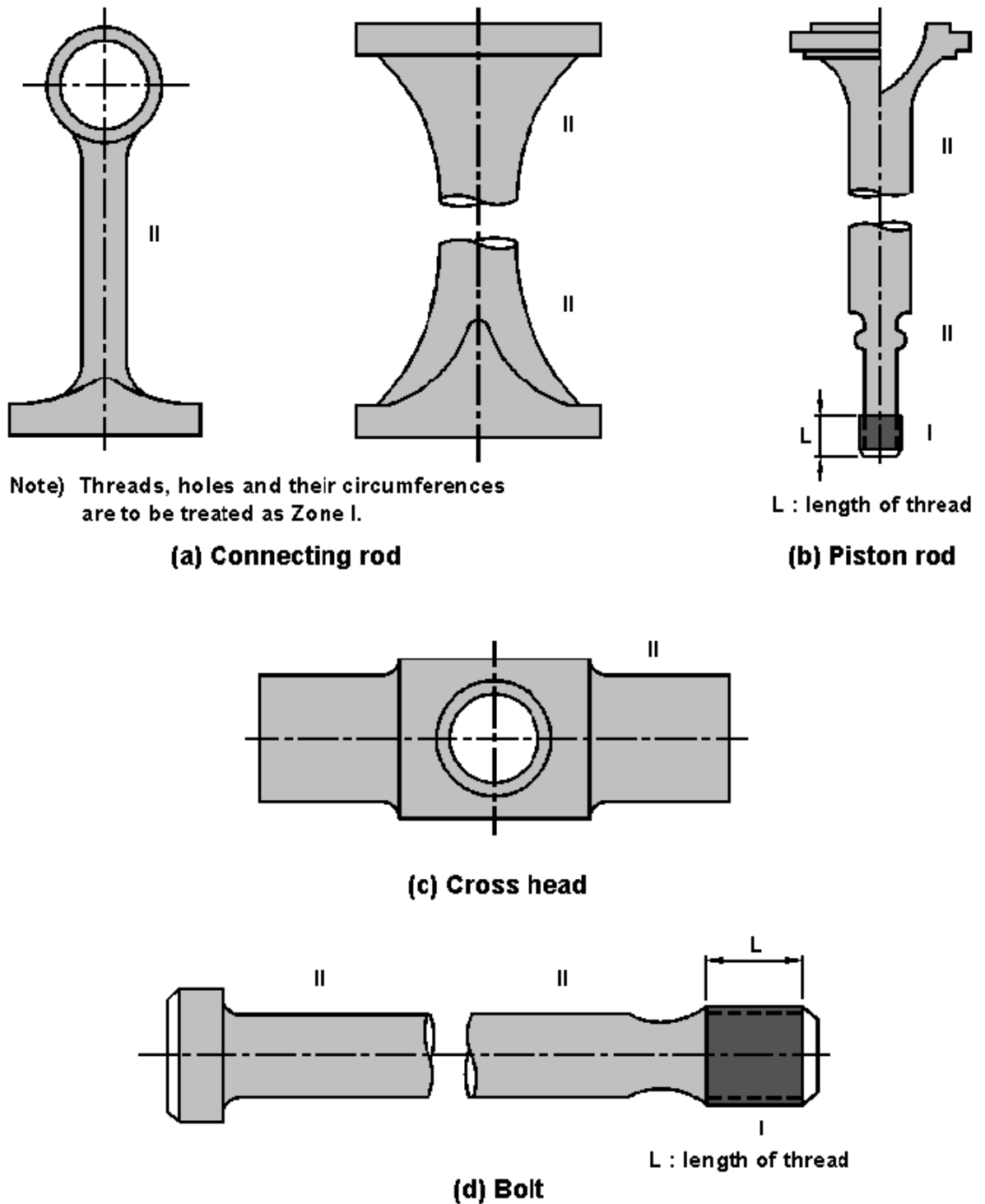

Fig. 3 : Zones for magnetic particle / liquid penetrant testing on machinery components

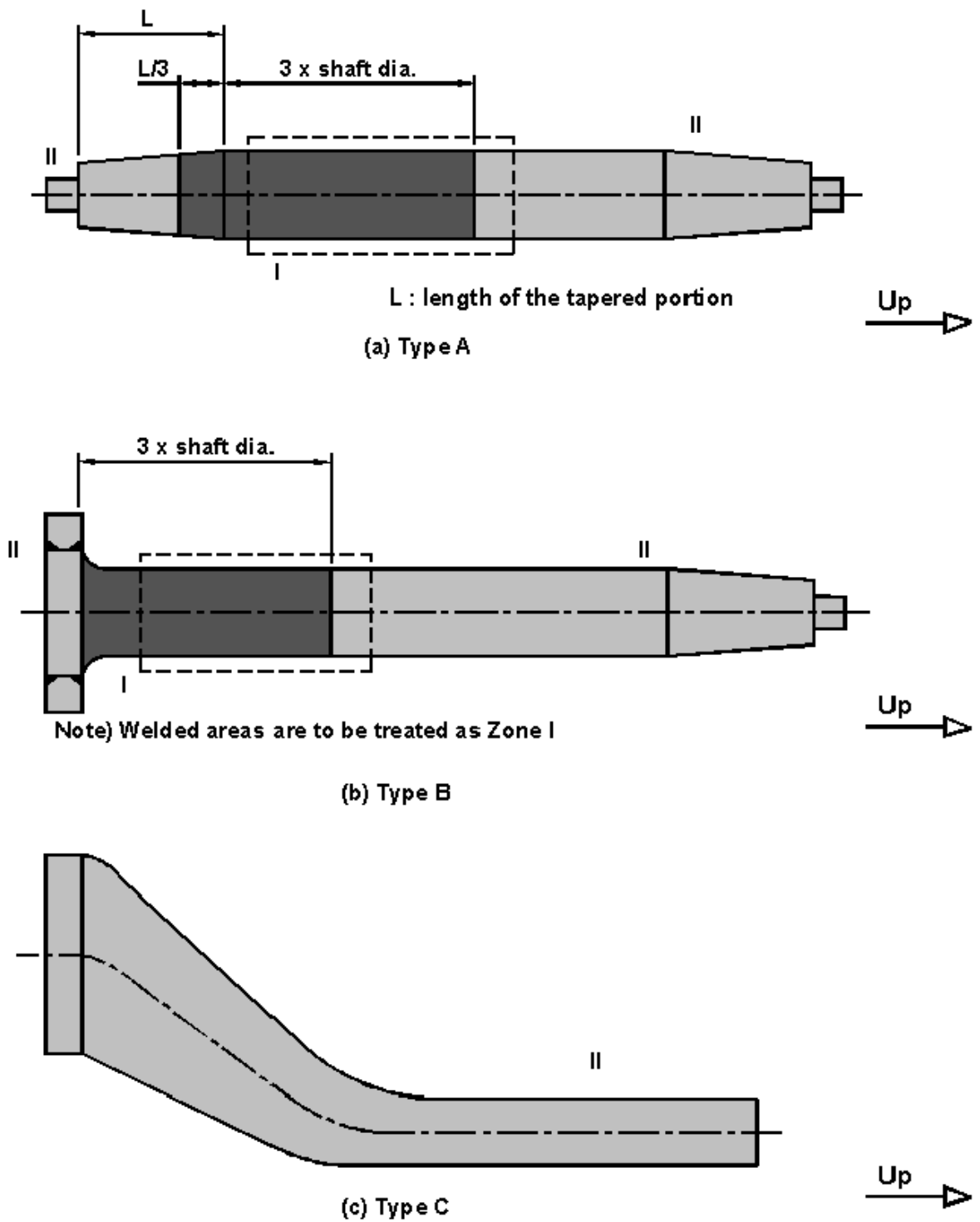

Fig. 4 : Zones for magnetic particle / liquid penetrant testing on rudder stocks

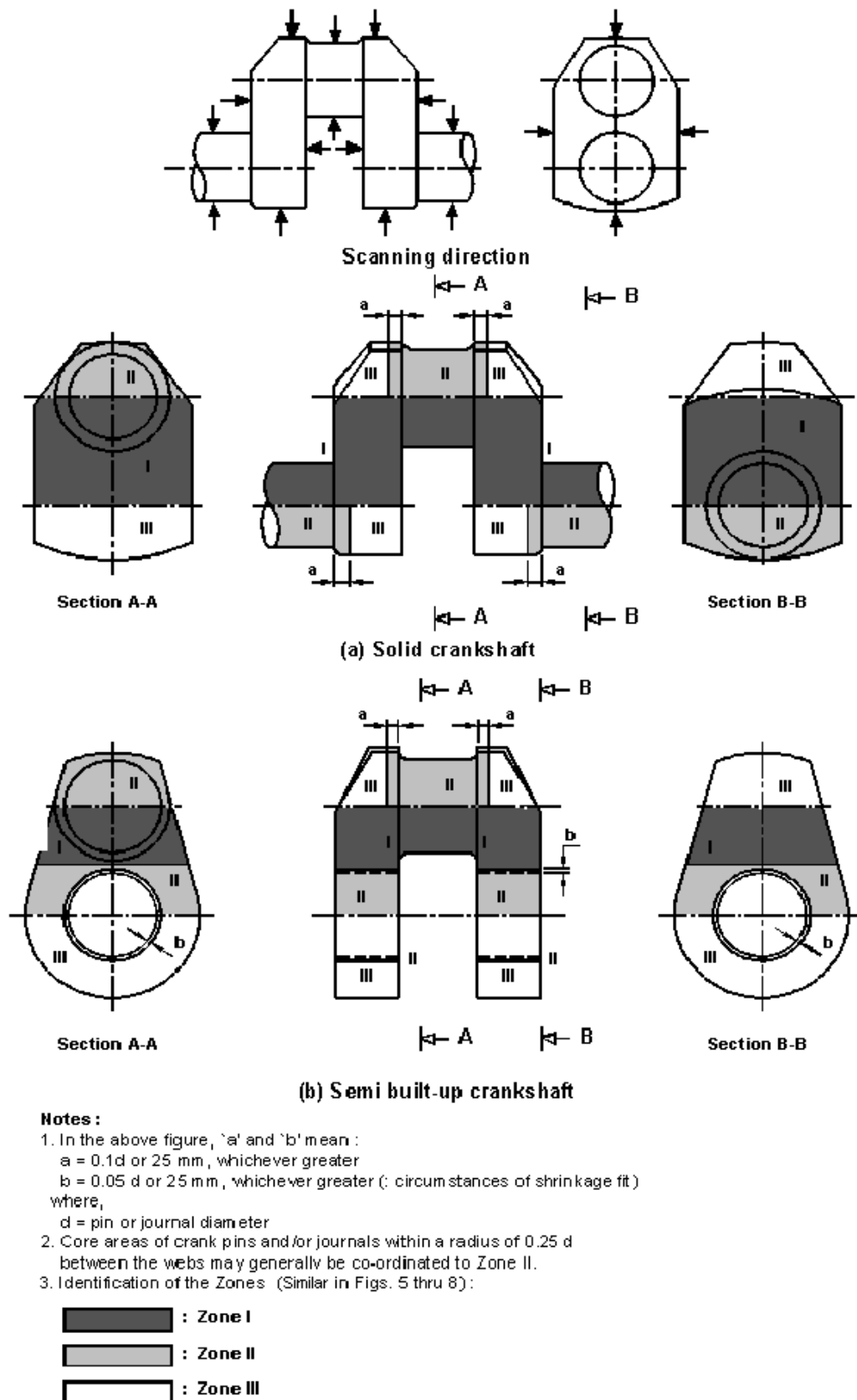
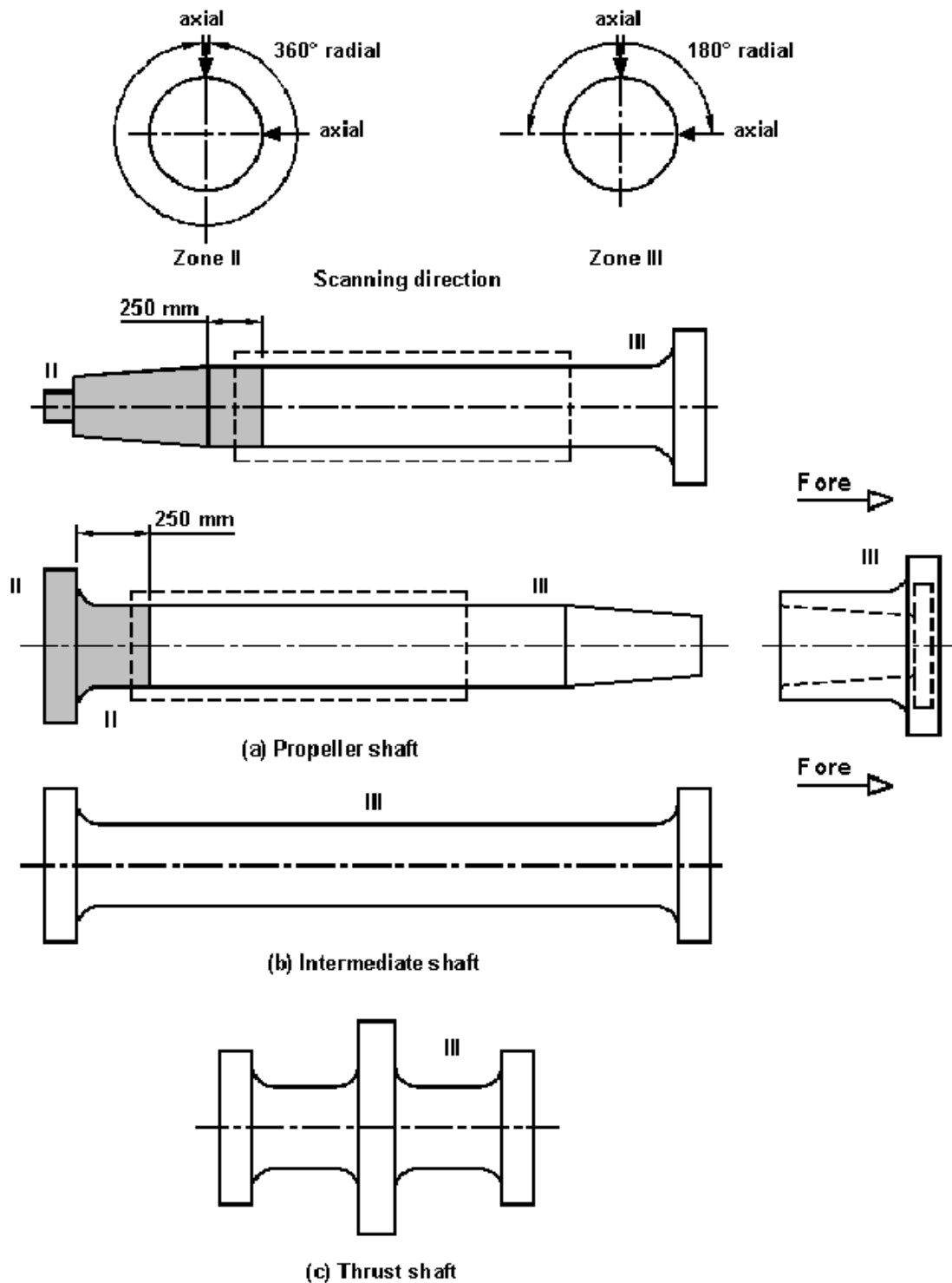

Fig. 5 : Zones for ultrasonic testing on crankshafts



- Notes :
1. For hollow shaft, 360° radius scanning applies to Zone III.
 2. Circumferences of the bolt holes in the flanges are to be treated as Zone II.

Fig. 6 : Zones for ultrasonic testing on shafts

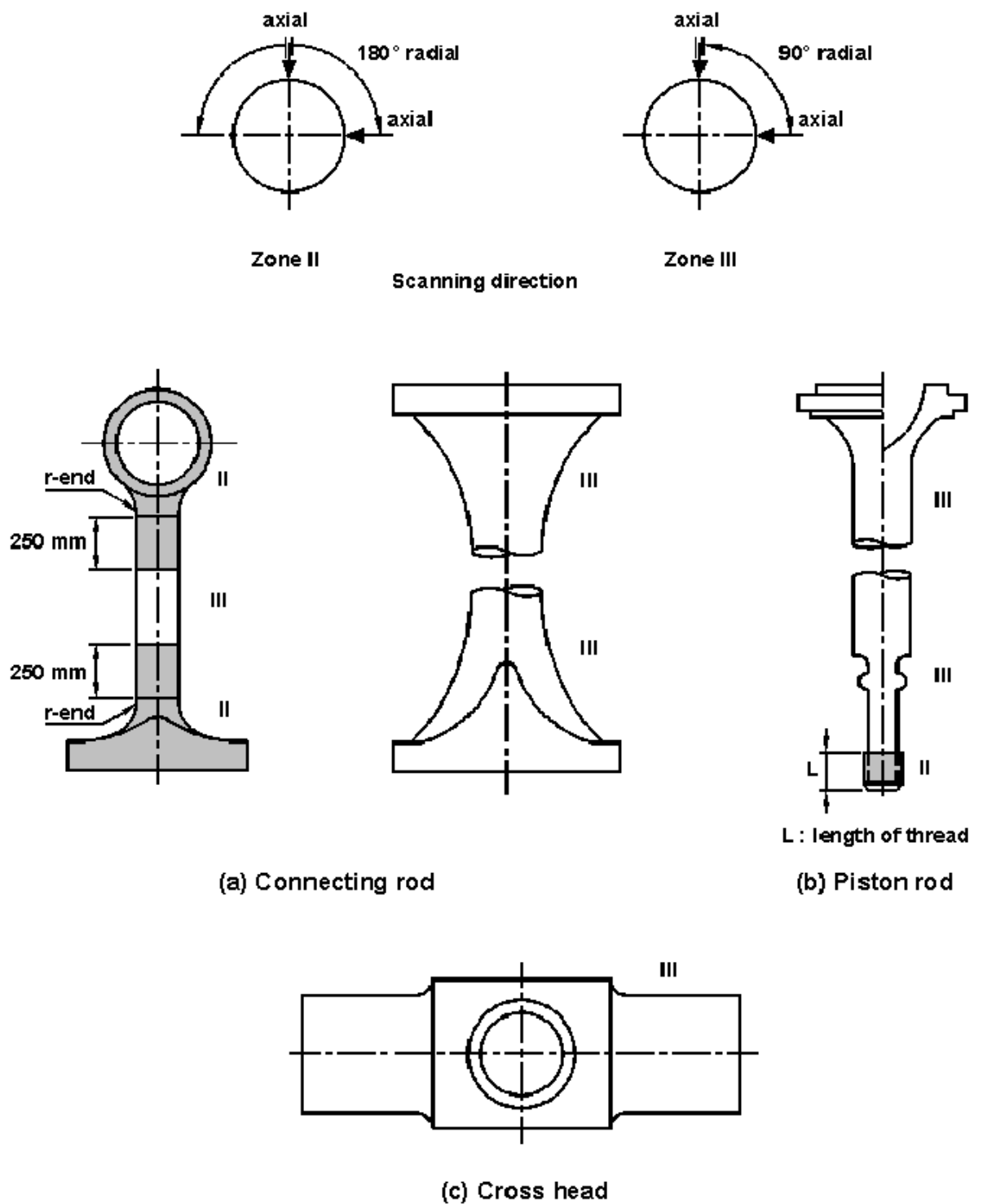

Fig. 7 : Zones for ultrasonic testing on machinery components

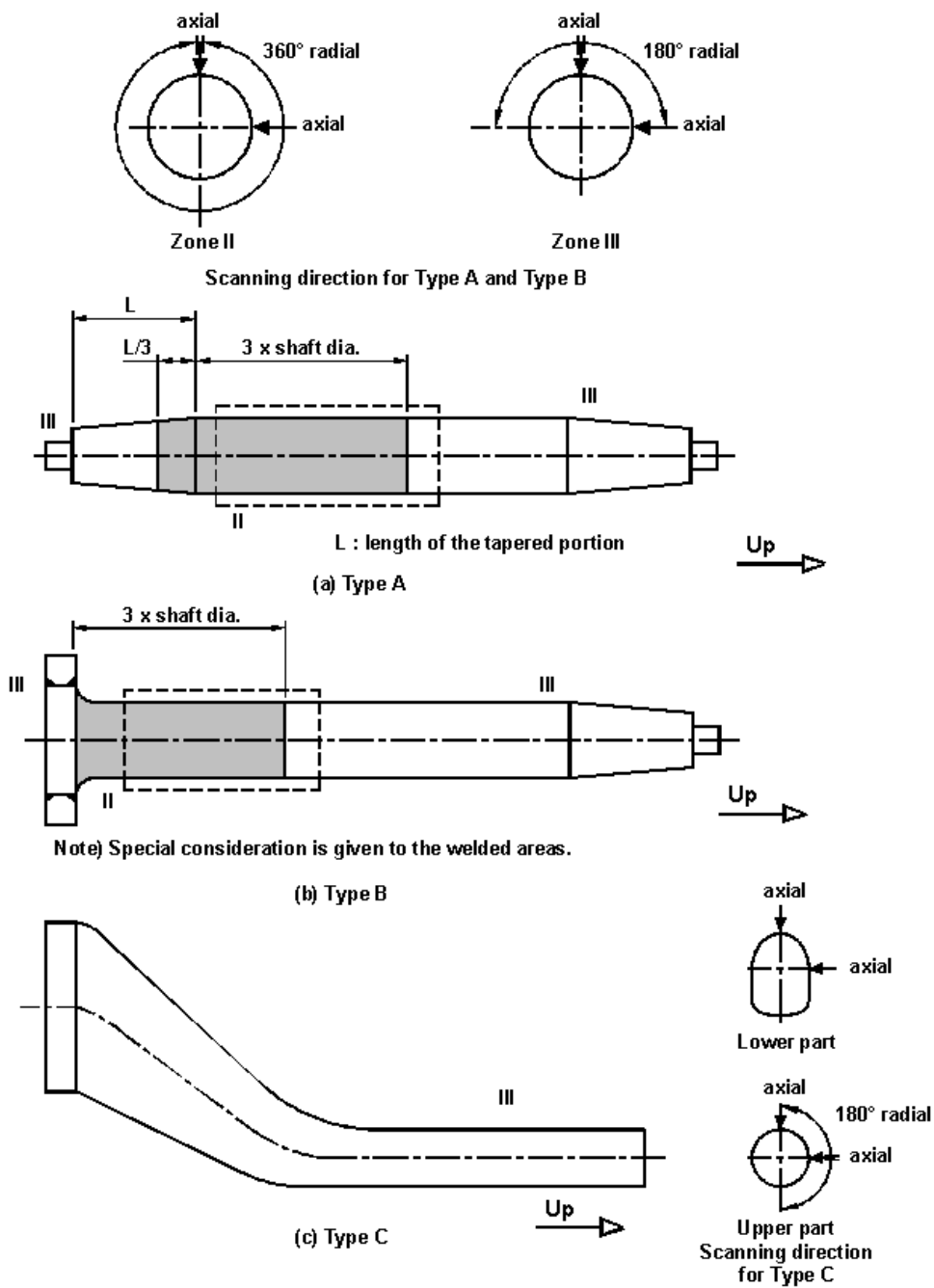

Fig. 8 : Zones for ultrasonic testing on rudder stocks